

Letecké závody a.s., 686 04 KUNOVICE
CZECH REPUBLIC

SAILPLANE FLIGHT MANUAL

Serial Nos.eligible : 029005 and subsequent

Model :

L 23 SUPER - BLANIK

Serial No. :

029016

Registration :

N438BA

Document No. : Do - L23 . 1014.5

Date of Issue : Jan 4, 2002

This sailplane Flight Manual is FAA Approved for U.S. - registered sailplanes in accordance with provision of 14 CFR Part 21.29, and as required by FAA Type Certificate Data Sheet No. **G60EU**.

Approved by the Civil Aviation Authority of the Czech Republic in Prague.

Signature :



Authority : CAA Prague

Stamp :



Original date of approval : March 15, 2002

This Sailplane Flight Manual must be carried in the sailplane at all times.

This sailplane is to be operated in compliance with information and limitations contained herein.



0.1 RECORD OF REVISIONS

Any revision or amendment of the present Manual will be issued in the form of Bulletins, approved by the Civil Aviation Authority of the Czech Republic, supplement of which will contain new (revised) pages. User's duty is to make a note about revisions in the Record of revisions and to replace existing pages with revised and effective ones. Revised or amended parts of the text will be indicated by a vertical line in the left hand margin and the revision No. and the date will be shown on the bottom left hand of the page.

Manufacturer's address: Letecké závody a.s.
686 04 KUNOVICE
CZECH REPUBLIC
Telephone: + 420-632-81 7650
Fax: + 420-632-81 7653
e-mail: ots@let.cz

Rev. No.	Affected Section	Affected pages	Date	Bulletin No.	Date of Bulletin approval	Date inserted and signature
1	0, 2, 6	0-1, 0-3, 2-3, 2-4, 6-6	Apr 9/02	L23/043a	Apr 24/02	



Rev. No.	Affected Section	Affected pages	Date	Bulletin No.	Date of Bulletin approval	Date inserted and signature



0.2 LIST OF EFFECTIVE PAGES

Pages identified as "Appr." provide information required to be furnished by the Federal Aviation Regulations.

Section	Page	Date	Section	Page	Date	
0	1	Apr 9/02	4	Appr 15	Jan 4/02	
	2	Jan 4/02		Appr 16	Jan 4/02	
	3	Apr 9/02		Appr. 17	Jan 4/02	
	4	Jan 4/02		Appr 18	Jan 4/02	
				Appr. 19	Jan 4/02	
				Appr. 20	Jan 4/02	
				Appr 21	Jan 4/02	
				Appr. 22	Jan 4/02	
1	1	Jan 4/02		5	Appr. 1	Jan 4/02
	2	Jan 4/02			Appr. 2	Jan 4/02
	3	Jan 4/02	Appr. 3		Jan 4/02	
	4	Jan 4/02	Appr. 4		Jan 4/02	
	5	Jan 4/02	Appr.5		Jan 4/02	
2	Appr. 1	Jan 4/02	6	1	Jan 4/02	
	Appr. 2	Jan 4/02		2	Jan 4/02	
	Appr. 3	Apr 9/02		3	Jan 4/02	
	Appr. 4	Apr 9/02		4	Jan 4/02	
	Appr 5	Jan 4/02		5	Jan 4/02	
	Appr. 6	Jan 4/02		6	Apr 9/02	
	Appr. 7	Jan 4/02		7	Jan 4/02	
	Appr. 8	Jan 4/02				
	Appr. 9	Jan 4/02				
	Appr. 10	Jan 4/02				
	Appr. 11	Jan 4/02				
	Appr. 12	Jan 4/02				
3	Appr 1	Jan 4/02	7	1	Jan 4/02	
	Appr. 2	Jan 4/02		2	Jan 4/02	
	Appr 3	Jan 4/02		3	Jan 4/02	
	Appr. 4	Jan 4/02		4	Jan 4/02	
				5	Jan 4/02	
4	Appr 1	Jan 4/02	8	1	Jan 4/02	
	Appr 2	Jan 4/02		2	Jan 4/02	
	Appr 3	Jan 4/02	9	1	Jan 4/02	
	Appr. 4	Jan 4/02		2	Jan 4/02	
	Appr 5	Jan 4/02		3	Jan 4/02	
	Appr 6	Jan 4/02				
	Appr 7	Jan 4/02				
	Appr. 8	Jan 4/02				
	Appr 9	Jan 4/02				
	Appr. 10	Jan 4/02				
	Appr. 11	Jan 4/02				
	Appr. 12	Jan 4/02				
	Appr. 13	Jan 4/02				
	Appr. 14	Jan 4/02				



0.3. TABLE OF CONTENTS

		Section
General	(a non-approved section)	1
Limitations	(an approved section)	2
Emergency procedures	(an approved section)	3
Normal procedures	(an approved section)	4
Performance	(a partly approved section)	5
Weight and balance	(a non-approved section)	6
Sailplane and systems description	(a non-approved section)	7
Sailplane handling, care and maintenance	(a non-approved section)	8
Supplements	(a partly approved section)	9



SECTION 1

General

CONTENTS

- 1.1 Introduction
- 1.2 Certification basis
- 1.3 Warnings, cautions and notes
- 1.4 Descriptive data
 - 1.5.1 Three-view drawing - Dimensions in ft
 - 1.5.2 Three-view drawing - Dimensions in mm



1.1 INTRODUCTION

The sailplane flight manual has been prepared to provide pilots with information for the safe and efficient operation of the L 23 SUPER-BLANIK sailplane. This manual includes the material required to be furnished to the pilot by JAR - 22. It also contains supplemental data supplied by the sailplane manufacturer.

1.2 CERTIFICATION BASIS

This type of sailplane has been approved by the Civil Aviation Authority of the Czech Republic in accordance with JAR-22, Change 4 issued April 1, 1980 including Amendment 22/86/1 Eff. Oct. 22, 1986 and AC 21.17-2.

1.3 WARNINGS, CAUTIONS AND NOTES

The following definitions apply to warnings, cautions and notes used in the Flight Manual.

WARNING: **MEANS THAT THE NON-OBSERVATION OF THE CORRESPONDING PROCEDURE LEADS TO AN IMMEDIATE OR IMPORTANT DEGRADATION OF THE FLIGHT SAFETY**

CAUTION: **means that the non-observation of the corresponding procedure leads to a minor or to a more or less long term degradation of the flight safety.**

Note: draws the attention on any-special item not directly related to safety but which is important or unusual.



1.4 DESCRIPTIVE DATA

The L 23 SUPER - BLANIK sailplane is a cantilever, high-wing, two-seat glider of all-metal structure. Wing tip extensions are optional.

Basic dimensions

Wing span 53.15 ft (16.2 m)
(with the installed wing tip extensions) 59.71 ft (18.2 m)

Note: If the wing tip with supporting
wheel is installed wing span is 53.35 ft (16.26 m)

Length 27.89 ft(8.5 m)

Height 6.23 ft(1.9 m)

Wing area 206.13 sq ft(19.15 sq.m)
(with the installed wing tip extensions) 215.27 sq ft(20.00sq.m)

Aspect ratio 13.7
(with the installed wing tip extensions) 16.6

Mean aerodynamic chord 4.11 ft(1.253 m)
(with the installed wing tip extensions) 3.99 ft(1.216m)



1.5.1 THREE - VIEW DRAWING (Dimensions in ft)

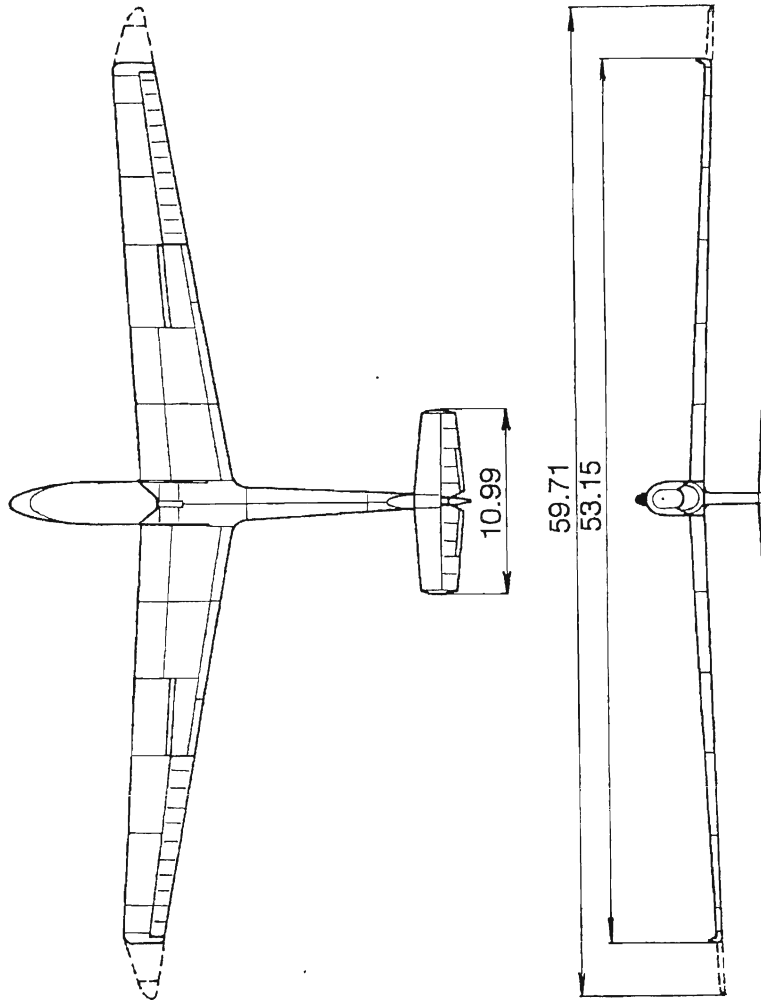
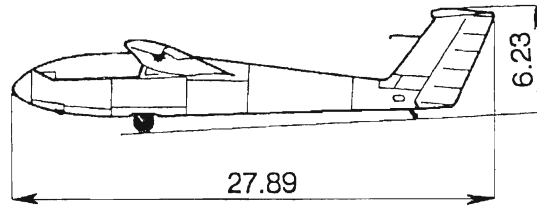



1.5.2 THREE - VIEW DRAWING (Dimensions in mm)

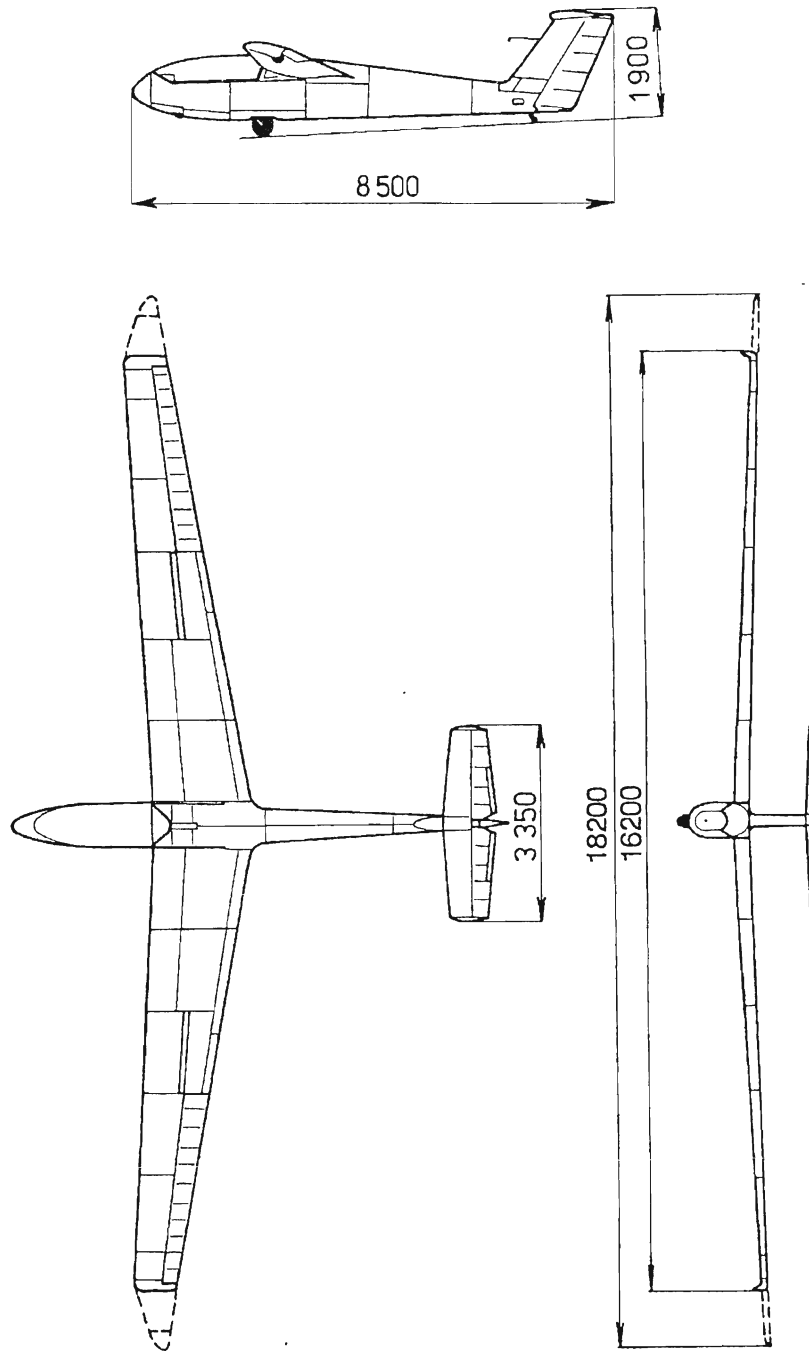



SECTION 2

Limitations

CONTENTS

- 2.1 Introduction
- 2.2 Airspeed
- 2.3 Airspeed indicator markings
- 2.4 Weight
- 2.5 Centre of gravity
- 2.6 Approved manoeuvres
- 2.7 Manoeuvring load factors
- 2.8 Flight crew
- 2.9 Kinds of operation
- 2.10 Minimum equipment
- 2.11 Aerotow and winch-launching
- 2.12 Other limitations
- 2.13 Limitation placards



2.1 INTRODUCTION

Section 2 includes operating limitations and basic placards necessary for safe operation of the sailplane, its standard systems and standard equipment. The limitations in this section are FAA approved by the CAA, Czech Republic. The values in parentheses are valid only when using wing tip extensions.

2.2 AIRSPEED

Speed		KIAS (km/h IAS)	Remarks
V _{NE}	Never exceed speed up to a pressure altitude of 13,780 ft (4200 m)	124 (230)	Do not exceed this speed in any operation and do not use more than 1/3 of control deflection
V _{RA}	Rough air speed	81 (150)	Do not exceed this speed except in smooth air, and then only with caution. Examples of rough air are lee-wave rotor thunderclouds etc.
V _A	Manoeuvring speed	81 (150)	Do not make full or abrupt control movement above this speed, because under certain conditions the sailplane may be overstressed by full control movement
V _W	Maximum winch-launching speed	65 (120)	Do not exceed this speed during winch- or autotow-launching
V _T	Maximum aerotowing speed	81 (150)	Do not exceed this speed during aerotowing
V _{LO}	Maximum landing gear operating speed	124 (230)	Do not extend or retract the landing gear above this speed

Note: V_{NE} airspeed limits above 13,780 ft (4200 m) Pressure Altitude are reduced as follows:

Pressure Altitude ft *	13,780	20,000	25,000	30,000	35,000
V _{NE} KIAS	124 (124)	124 (114)	116 (105)	108 (97)	100 (89)

*- Altimeter Setting at 29.92 in.Hg (1013.25 hPa).



L 23 SUPER - BLANIK

686 04 KUNOVICE
CZECH REPUBLIC

SAILPLANE FLIGHT MANUAL

Do - L 23. 1014.5

Pressure Altitude m *	4,200	6,000	7,500	9,000	10,500
V _{NE} km/h IAS	230 (230)	230 (210)	215 (195)	200 (180)	185 (165)

2.3 AIRSPEED INDICATOR MARKINGS

Marking	KIAS (km/h IAS)	Significance
Green arc	36 - 81 (67-150)	Normal Operating Range. (Lower limit is maximum weight 1.1 v _{SI} at most forward c.g. Upper limit is rough air speed)
Yellow arc	81 - 124 (150-230)	Manoeuvres must be conducted with caution and only in smooth air.
Red line	124 (230)	Maximum speed for all operations
Yellow triangle	49 (90)	Approach speed at maximum weight.

2.4 WEIGHT LIMITS

Maximum take - off and landing weight:

- with two occupants 1168 lb (530 kg)

Empty weight

with standard equipment 683 lb ± 2 % (695 lb ± 2%) or

with standard equipment 310 kg ± 2 % (315 kg ± 2%)

and the corresponding centre

of gravity position 67.30 ± 1% MAC (68.30 ± 1% MAC)

Max. weight of all non lifting parts 822 lb (811 lb) or 373 kg (368 kg)

Note : Refer to weight and Balance (Section 6.0) to determine actual empty weight / c.g. as established by the installed equipment and manufacturing tolerances.

(Cont.)



Pilot's weight (including parachute):

- minimum pilot's weight (solo) 154 lb (70 kg)

It is necessary to use front seat removable ballast of 33 lb (15 kg) when flown solo by a pilot (including parachute) weighing less than 154 lb (70 kg) in the front cockpit

Note: Installation of the front seat ballast is described in Section 7, paragraph 7.2 of this Flight Manual

- maximum pilot's weight (solo) 287 lb (130 kg)

Maximum useful load (occupants,
baggage, optional equipment) 485 lb (475 lb) or 220 kg (215 kg)

Maximum baggage compartment load 22 lb (10 kg)



2.5 CENTRE OF GRAVITY

Centre of gravity range

- front limit 23 % MAC i.e. 4.397 in
(112 mm) aft of
reference datum

- rear limit 40 % MAC i.e. 12.783 in
(325 mm) aft of
reference datum

Wing tip extensions installation moves the center of gravity of the empty sailplane 1% MAC (0.493 in = 12.53 mm) to the back.

The reference datum is located 93.6 in (2.37 m) aft of the sailplane nose.

2.6 APPROVED MANOEUVRES (UTILITY CATEGORY)

Sailplane is certified in the Utility Category.
With the installed wing tip extensions all aerobatic manoeuvres are prohibited.

Manoeuvre	Airspeeds - KIAS				Procedures
	SOLO	DUAL	ENTRY	RECOVERY	
Loop	86	97	X		Section 4.4.6 item 1.
Stall turn	92	97	X		Section 4.4.6 item 2.
Lazy Eight	97	97	X		Section 4.4.6 item 3.
Spin	32 86	32 86	X	X	Section 4.4.6 item 4.
Chandelle(climbing)	97	97	X		Section 4.4.6 item 5.
Steep turn	92	97	X		Section 4.4.6 item 6.



2.7 MANOEUVRING LOAD FACTORS

It is valid for maximum weight of the sailplane.

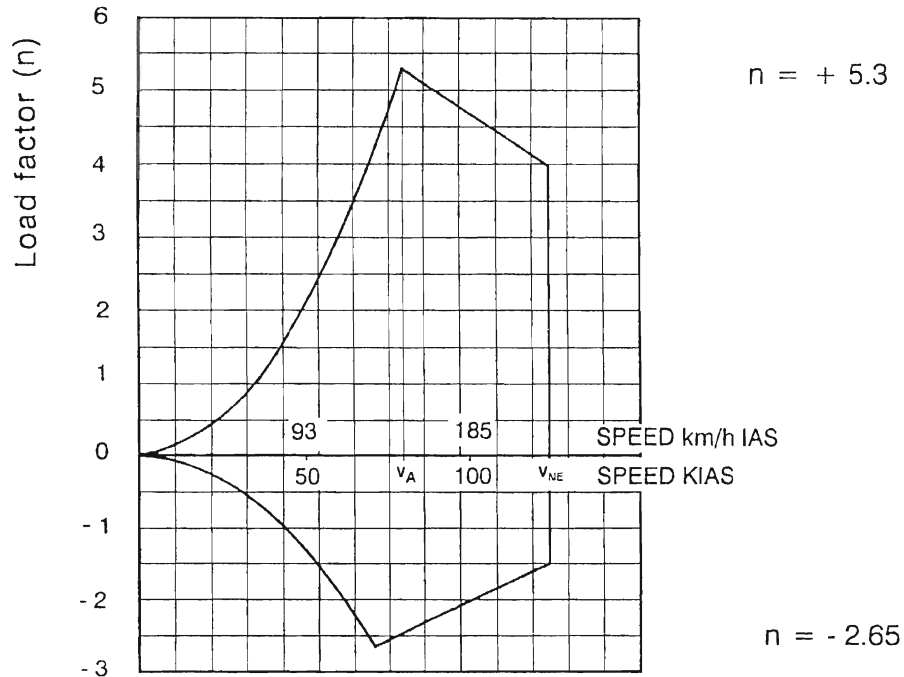

FIG. 2 - 1

2.8 FLIGHT CREW

Minimum - one pilot. Maximum number of occupants is two. If the sailplane is to be flown solo, the pilot must be sitting in the front seat and his weight (including parachute) must be 154 lb (70 kg) at least. If the pilot's weight is less than 154 lb (70 kg), it is necessary to use the cushion with 33 lb (15 kg) ballast.

WARNING: THE REAR SEAT MUST BE SECURED AGAINST FOLDING AND SAFETY HARNESSSES ON THE REAR SEAT MUST BE CONNECTED, DRAWN TOGETHER AND SECURED.

2.9 KINDS OF OPERATION

The sailplane is approved for Day VFR operations. Cloud-flying is permitted where operational regulations permit, and the minimum required equipment is installed and operable.

(Cont.)



- WARNING:**
1. OPERATIONS IN ICING CONDITIONS ARE PROHIBITED. OPERATIONS ARE LIMITED BY THE INSTALLED EQUIPMENT AS LISTED IN SECTION 6.
 2. AEROBATIC FLIGHT TIME MUST BE RECORDED IN THE SAILPLANE LOG BOOK TO COMPLY WITH CONTINUED AIRWORTHINESS REQUIREMENTS.
 3. ALL AEROBATIC MANOEUVRES ARE PROHIBITED WITH INSTALLED WING TIP EXTENSION.
 4. WITH INSTALLED WING EXTENSIONS:
ALL FLIGHT TIME WITH WING EXTENSIONS MUST BE RECORDED IN THE SAILPLANE LOG BOOK TO COMPLY WITH CONTINUED AIRWORTHINESS REQUIREMENTS.
 5. THE NUMBER OF WINCH AND AEROTOW LAUNCHES MUST BE RECORDED IN THE SAILPLANE LOG BOOK TO COMPLY WITH CONTINUED AIRWORTHINESS REQUIREMENTS.

2.10 MINIMUM EQUIPMENT

Instruments and minimum equipment must be approved types.

A. Instruments All Operations:

- Airspeed indicator
- Altimeter
- Lap and shoulder straps

B. Additional Instruments required for Cloud flying:

- Magnetic compass
- Turn and bank indicator
- Variometer (Vertical Speed Indicator)



2.11 AEROTOW AND WINCH LAUNCHING

Aerotow

- the maximum cable strength or cable safety device (weak link) strength is 1460 lb (6500 N).
- maximum permissible speed $V_T = 81$ KIAS (150 km/h IAS)
- the minimum cable length for aerotowing is 50 ft (15 m), recommended length is 100-130 ft (30 - 40 m).

Winch-launching

- the maximum cable strength or cable safety device (weak link) is 1460 lb (6500 N).
- maximum permissible speed $V_W = 65$ KIAS (120 km/h IAS)

2.12 OTHER LIMITATIONS

A. Maximum crosswind component

- maximum demonstrated crosswind component for safe approach, landing and aerotow launching is 16 kt (8 m/s) for angle 90^0 .

Maximum demonstrated crosswind component for winch-launching:

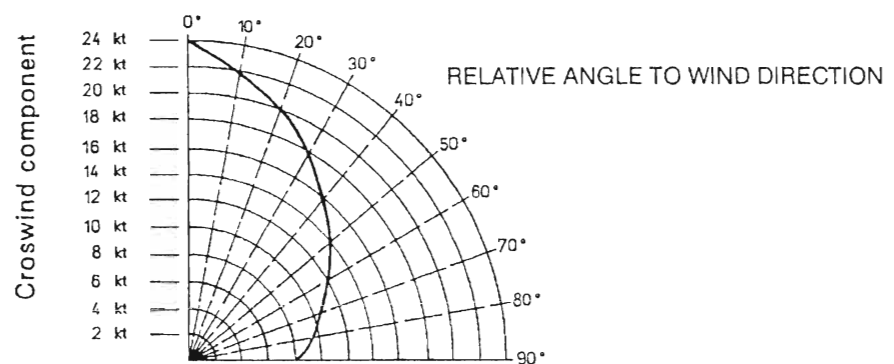

FIG. 2 - 2

B. Maximum demonstrated operating altitude - 13, 780 ft (4,200 m)

(Cont.)



C. Maximum Tire Pressure 37 psi (250 kPa).

D. Continued Airworthiness Life Limits:

The initial sailplane service life is specified to 6000 flight hours and 30000 landings under the following operating conditions:

- Max. 4.83 take-offs per 1 flight hour;
- The winch launching - aerotow take-off ratio is 5 : 1;
- Crew: 35% double, 65% single;
- Elementary training-to-advanced training and to performance soaring ratio is 40% : 60%, whereby the aerobatics share is 2% of the total operation.

Sailplane life L_B versus operation with wing tip extensions is
 $L_B = 6000 - 25.x$ (where x is operation with wing tip extensions in percents of the total operation time)

E. Max. loads factors are marked by a red line on the accelerometer:

$$n = +5.3$$

$$n = -2.65$$



2.13 LIMITATIONS PLACARDS

The following operating limitations are emphasized on the limitation placards in both cockpits:

a) front cockpit

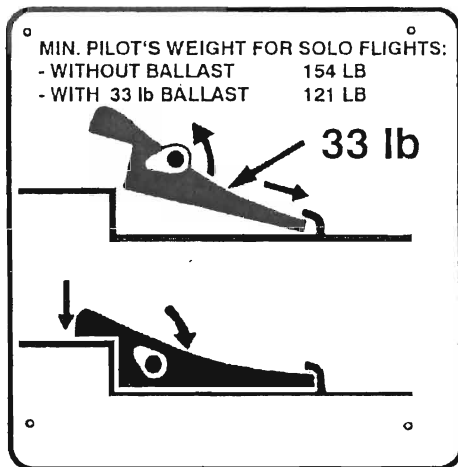

or

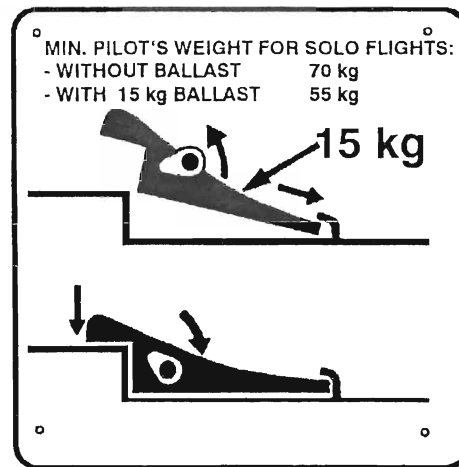

SEAT BACK



PEDAL ADJUSTMENT

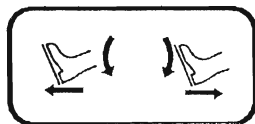

AIR VENT

CENTRE OF GRAVITY RANGE
 FRONT LIMIT . 23 % MAC
 REAR LIMIT . . 40 % MAC

b) both front and rear cockpits

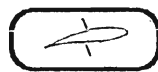

AIR BRAKES

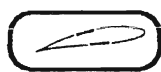

CANOPY LIFT OFF



or

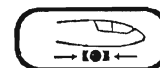

WHEEL BRAKE



LANDING GEAR



CANOPY JETTISON
see para 3.2.2

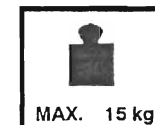

BAGGAGE
(REAR SEAT ONLY)



L 23 SUPER - BLANIK

686 04 KUNOVICE
CZECH REPUBLIC

SAILPLANE FLIGHT MANUAL

Do - L 23. 1014.5

On customer's request:

MAX. ALLOWABLE SPEED VS ALTITUDE					
PRESSURE ALTITUDE (FT) UP TO	13 780	20 000	25 000	30 000	35 000
WITHOUT EXTENSIONS	124	124	116	108	100
WITH EXTENSIONS	124	114	105	97	89

or

MAX. ALLOWABLE SPEED (km/h IAS) VS ALTITUDE					
PRESSURE ALTITUDE (m) UP TO	4200	6000	7500	9000	10500
WITHOUT EXTENSIONS	230	230	215	200	185
WITH EXTENSIONS	230	210	195	180	165

If installed wing tip extensions:

ALL AEROBATIC MANOEUVRES
ARE PROHIBITED WITH
INSTALLED WING TIP EXTENSIONS



TRIMMER

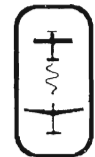

RELEASE

V_{NE} 124 KIAS

V_{RA} 81 KIAS

or

V_{NE} 230 km/h IAS

V_{RA} 150 km/h IAS

Valid when **lower or side hook** is installed :

MAX. WINCH - LAUNCHING SPEED	65 KIAS
MAX. AERO - TOWING SPEED	81 KIAS
MAX. MANOEUVRING SPEED	81 KIAS

or

MAX. WINCH - LAUNCHING SPEED	120 km/h IAS
MAX. AERO - TOWING SPEED	150 km/h IAS
MAX. MANOEUVRING SPEED	150 km/h IAS

Valid when **front hook only** is installed :

MAX. AERO - TOWING SPEED	81 KIAS
MAX. MANOEUVRING SPEED	81 KIAS

or

MAX. AERO - TOWING SPEED	150 km/h IAS
MAX. MANOEUVRING SPEED	150 km/h IAS



OPERATING LIMITATIONS

**THIS GLIDER MUST BE OPERATED
IN COMPLIANCE WITH THE OPERATING
LIMITATIONS STATED IN THE FORM
OF PLACARDS, MARKINGS AND MANUALS**

MAX. GROSS WEIGHT 1168 LB

APPROVED MANOEUVRES:

LOOP SPIN

STALL TURN CHANDELLE(Climbing)

LAZY EIGHT STEEP TURN

SOLO FLIGHT FROM FRONT SEAT ONLY

or

OPERATING LIMITATIONS

**THIS GLIDER MUST BE OPERATED
IN COMPLIANCE WITH THE OPERATING
LIMITATIONS STATED IN THE FORM
OF PLACARDS, MARKINGS AND MANUALS**

MAX. GROSS WEIGHT 530 kg

APPROVED MANOEUVRES:

LOOP SPIN

STALL TURN CHANDELLE(Climbing)

LAZY EIGHT STEEP TURN

SOLO FLIGHT FROM FRONT SEAT ONLY

c) exterior markings

Near the static pressure sensor.

STAT



SECTION 3

Emergency procedures

CONTENTS

- 3.1 Introduction
- 3.2 Canopy jettison
- 3.3 Bailing Out
- 3.4 Stall recovery
- 3.5 Spin recovery
- 3.6 Spiral Dive Recovery



3.1 INTRODUCTION

Section 3 provides check-lists and amplified procedures for handling emergency situations.

3.2.2 CANOPY JETTISON (SEE FIG. 3 - 1)

Front or rear pilot

Red Canopy Jettison Lever

ROTATE fully counterclockwise and HOLD.

Canopy

FORCE UPWARDS.

3.3 BAILING OUT

Safety Belts

RELEASE and REMOVE from lap and shoulders

Hand Holds

GRASP. STOOP legs below you BAIL OUT over the side cockpit rail.

3.4 STALL RECOVER

Low Speed Stall (One g)

PUSH control stick slightly. CHECK airspeed within normal operation range.

Stall at Speed (Accelerated)

PUSH control stick to reach subcritical angle of attack. ELIMINATE bank by rudder.

3.5 SPIN RECOVERY

Rudder

APPLY full deflection opposite to sense of rotation RETURN to neutral when rotation stopped.

Control Stick

PUSH forward slightly simultaneously as rudder is neutralized after rotation has stopped.

(Cont.)



3.6 Spiral Dive Recovery

Rudder and ailerons

USE to establish at nose - low wings level condition

Control stick

INCREASE gently back pressure to raise the nose to a level flight attitude. Use caution not to obtain excessive accelerations (g) with back pressure during the pull - up.



CANOPY JETTISON DURING FLIGHT

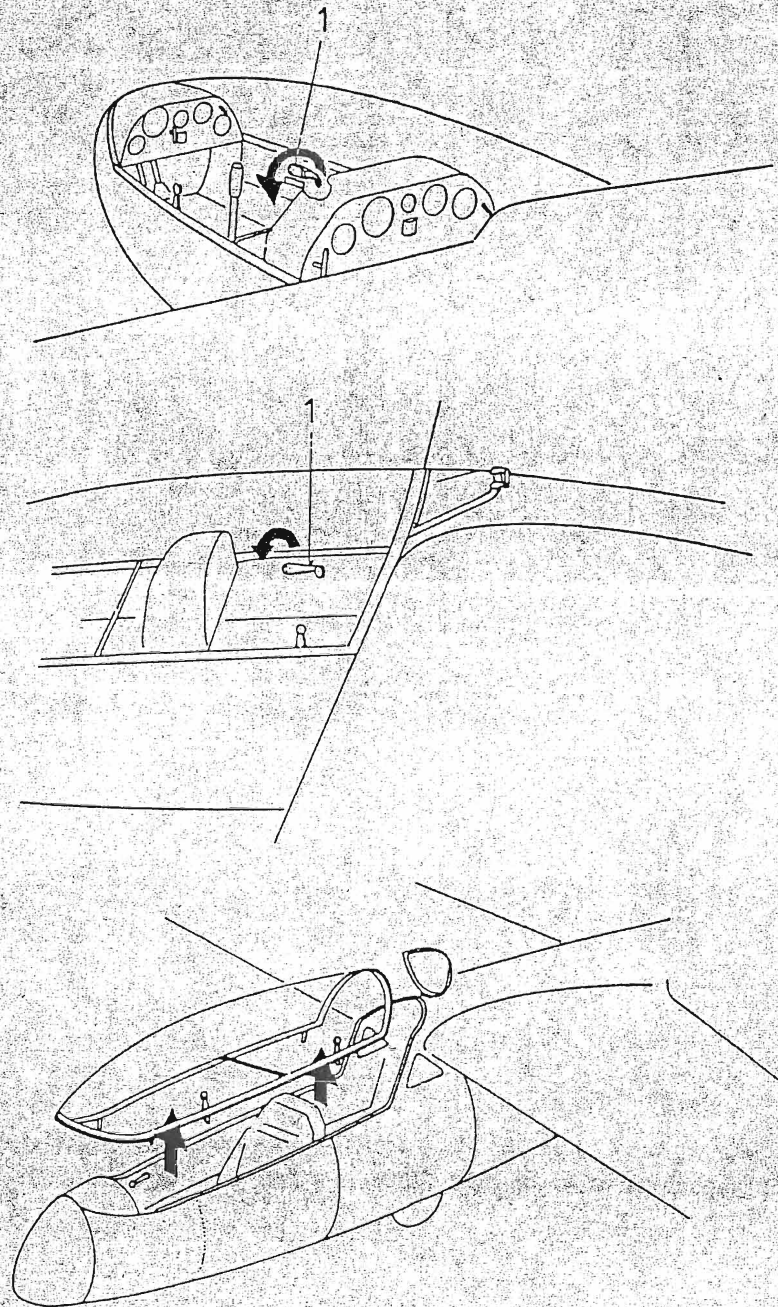

FIG. 3 - 1



SECTION 4

Normal procedures

CONTENTS

- 4.1 Introduction
- 4.2 Rigging and de-rigging
- 4.3 Preflight Inspection
- 4.4 Normal operations and recommended speeds
 - 4.4.1 Take-off and climb
 - 4.4.2 Flight
 - 4.4.3 Approach
 - 4.4.4 Landing
 - 4.4.5 Use of air brakes
 - 4.4.6 Basic aerobatics



) **4.1 INTRODUCTION**

Section 4 provides checklists and information on recommended procedures for normal operation.

4.2 RIGGING AND DE-RIGGING

A.Wing removal

Four people are needed for the wing removal. The first holds the fuselage, the second holds the wing tip, the third and the fourth hold the wing root (see Fig. 4-0). Level the sailplane to the horizontal position. Take off the fairings between the fuselage and the wing. Uncouple the aileron control tie rods by unlocking safety pins and removing pins on rocker levers, pivoted in consoles on the ribs No.1 (from the fuselage side). Remove lock pins out of both front hinge pins and wing main pins and knock out the front pin. Remove electrical ground strap. Move the wing gently up and down when installing or removing the pins. Pull the wing from the fuselage by slow careful movement and sit the wing vertically with the leading edge down on the special handling equipment.

B.Wing installation

The process of wing installation is the opposite. For easier installation of the centre hinge pins use the centering pin (or installation drift pin) before inserting the main pins (see Fig. 4-0, Detail A). When slipping wing hinges on fuselage hinges make sure that the globular joint of the air brakes control (see Fig. 4-0, Detail B) will be positioned to fit into the control drivers in the wing.

When assembling first slide in the wing main hinge pin and then the wing front hinge pin.

C.Removal and installation of the wing tip extensions

Remove 12 bolts at the last wing rib fixing the wing tip and remove the wing tip and/or wing tip extension.

Perform the installation in the reverse order. Insert the extension and/or by its guiding into the guiding tube at the last wing rib, adjust it in the proper position and fix with original bolts (10 pieces of M4 sunk bolt and 2 pieces of M5 fitted bolt with cylinder head) at both the wing ends. Tighten all the screws and bolts.

(Cont.)

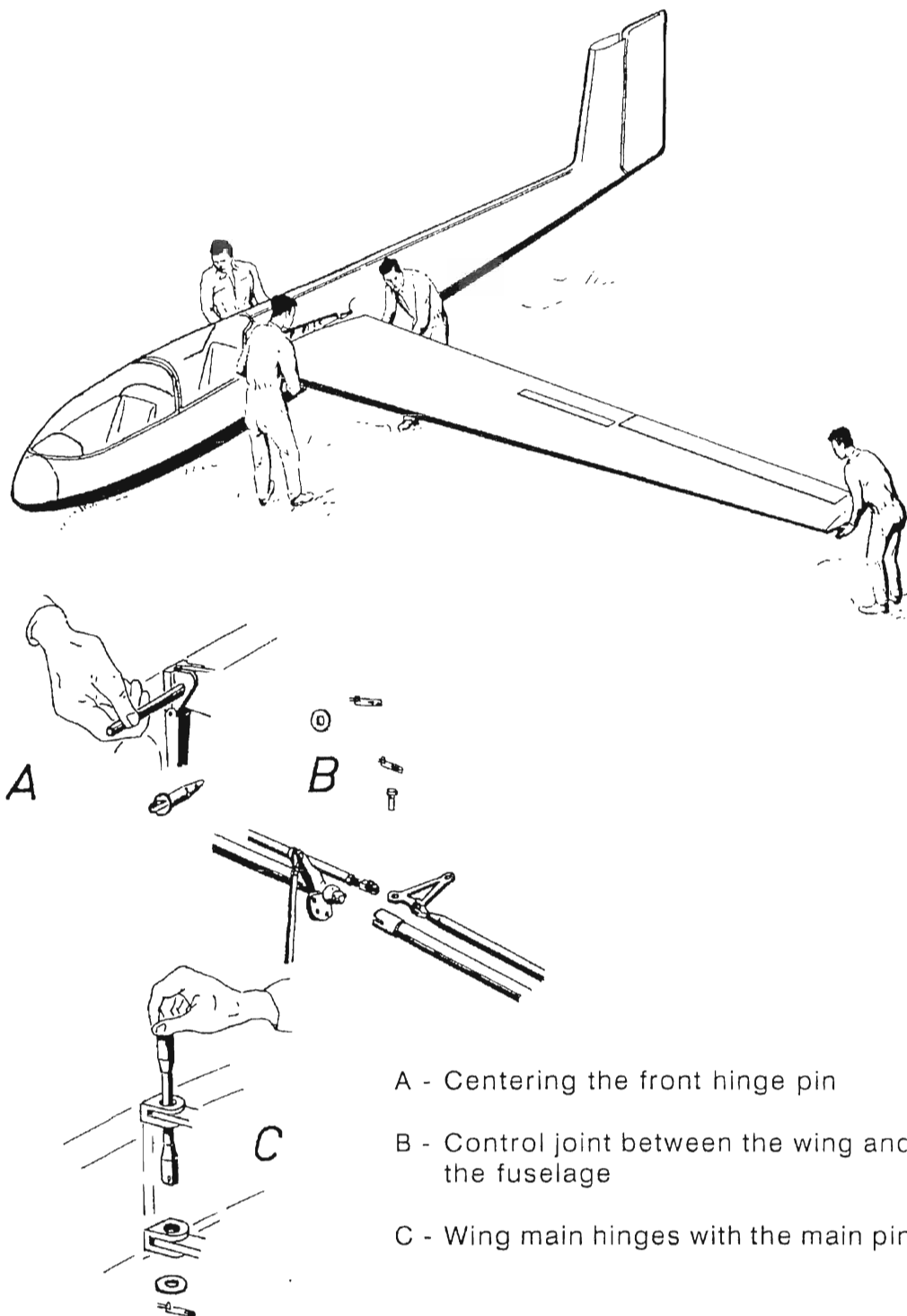

- A - Centering the front hinge pin
- B - Control joint between the wing and the fuselage
- C - Wing main hinges with the main pin

FIG. 4 - 0



D.Horizontal stabilizer installation

The process of horizontal stabilizer installation is the opposite. It is recommended that the horizontal stabilizer and the automatic connection rocker levers of the elevator trim tab control on the vertical stabilizer, and on the horizontal stabilizer, are approximately parallel.

E.Horizontal stabilizer removal

Remove the safety wire from the front pin of the horizontal stabilizers (in front of the leading edge of the vertical stabilizer on its top). Rotate the pin handle 180° and pull out the pin. Elevate the horizontal stabilizer leading edge about 30° up, slip out the horizontal stabilizers from pins by pulling forward. It is recommended that the elevator to be in the neutral position during removal. Put the horizontal stabilizers on the special handling equipment support.

4.3 PREFLIGHT INSPECTION

The pilot must check the sailplane for proper condition in accordance with the checklist walkaround inspection (before getting into the sailplane). It is recommended to perform the inspection as show in Fig.4-1.



Sequence of the walkaround inspection

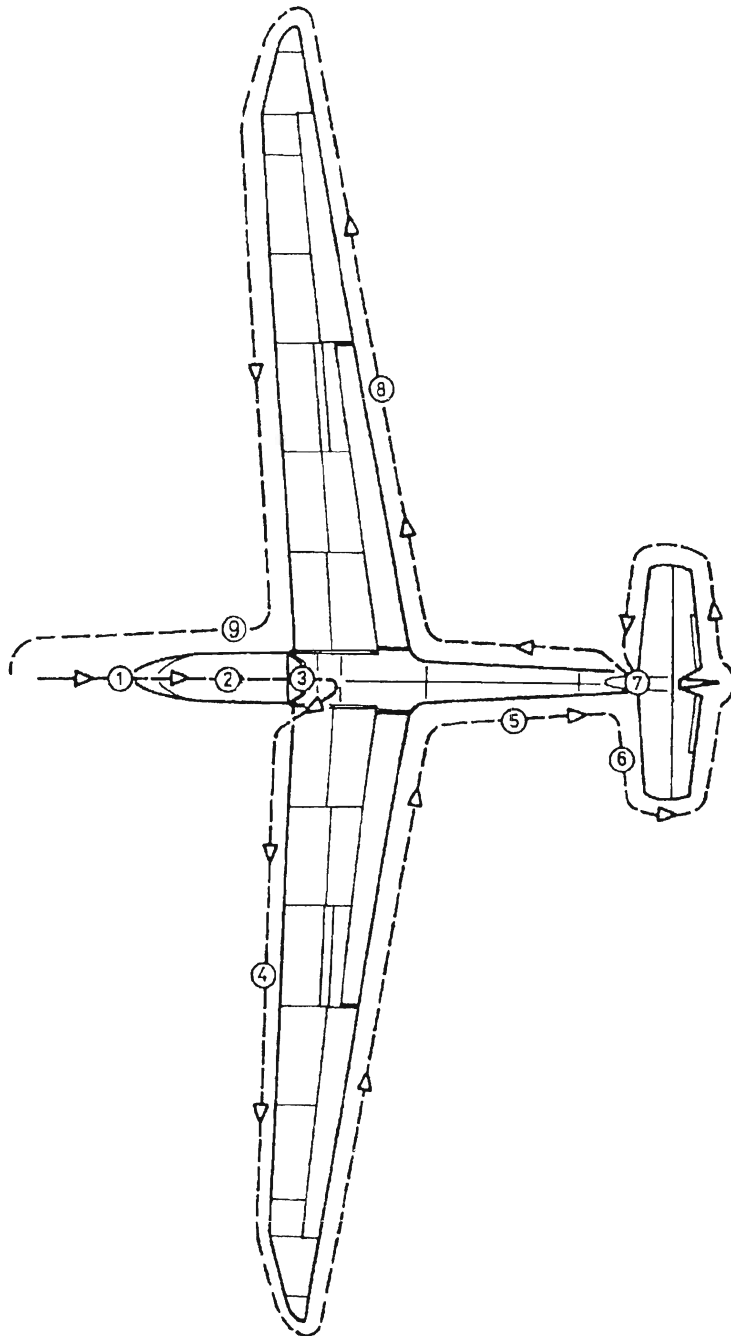

FIG. 4 - 1

(Cont.)

4.3.1 WALKAROUND INSPECTION CHECKLIST

Item No.	Subject	Check/activity
1	<u>Front fuselage section</u>	
	Fuselage skin	no damage
	Left & right static probes	ports clear
	Cockpit canopy surface	no damage or dirt
	Nose pitot tube	no damage or clogging
2	<u>Cockpit</u>	
	Instruments	no damage
	Altimeters	correct setting QFE (QNH)
	Radio station (if installed)	proper operation
	Front ventilation	for season
	Safety belts	no damage
3	<u>Landing gear</u>	
	Tire	no damage, correct inflation
4	<u>Left wing</u>	
	Wing skin including leading edge	no damage
	Wing-tip fairing (wing tip extension)	no damage or loose
	Aileron skin	no damage to fabric cover or trailing edge
	Ailerons	free movement
	Airbrake locking hinges	locking no damage of hinges or control tie rods

(Cont.)



L 23 SUPER - BLANIK

686 04 KUNOVICE
CZECH REPUBLIC

SAILPLANE FLIGHT MANUAL

Do - L 23. 1014.5

Item No.	Subject	Check/ activity
5	<u>Rear fuselage section</u>	
	Inspection ports	cables, fasteners snug
	Fuselage skin	no damage
6	<u>Empennage</u>	
	Vertical stabilizer	no damage
	Compensator pickup	in place, plug removed
	Elevator	free movement
	Horizontal stabilizers	condition of locking wire on the front pin of the horizontal stabilizer (in front of the leading edge of the top part of the vertical stabilizer)
	Rudder	free movement
7	<u>Tail landing gear</u>	
	Landing gear attachment	no damage of attachment
8	<u>Right wing</u>	see Item 4 - left wing
9	<u>Front fuselage section</u>	
	Pins for canopy opening	proper position against hinges



4.3.2 BEFORE TAKE-OFF CHECKLIST

Front seat

Before entering the front cockpit, adjust the front seat back-rest to a position allowing control of the sailplane when fully strapped in.

Rudder control

The position of the rudder pedals should be adjusted with the pilot fully strapped in so that both left and right pedals can be moved comfortably to the full extent of their travel. The position of the rudder pedals in the front cockpit can be adjusted by means of the crank. In the rear cockpit, adjustment to one of three possible positions may be obtained by removing the locking pin.

Note: This can be done only before the flight.

Control column

Check for full and free movement of the control column in all directions; move it to the left, to the right, forwards and backwards.

Instruments

Set the altimeters to zero or as desired by the baro-set knob. Check the other instruments and see that vertical speed indicators and airspeed indicators read zero.

Cockpit canopy

Close and lock.

Safety belts

Fasten the safety belts.

Trim

Set the elevator trim tab to the neutral position marked "0" .

Air brakes

Check for easy movement of air brake control. Confirm air brakes retracted for take off.

Tow rope release

Check the tow rope release mechanism for proper functioning.



4.4 NORMAL OPERATIONS AND RECOMMENDED SPEEDS

4.4.1 TAKE-OFF AND CLIMB

1. Aerotow launching

The take-off technique by aerotow is entirely conventional. The elevator and rudder efficiency is high enough during the initial stages of the take-off run, that it is easy to prevent directional or roll oscillations by use of rudder or ailerons, Set the elevator trim tab control to a position between "zero" and "nose heavy" and hold the control stick in the neutral position - on the landing gear and at liftoff speed pull the control stick gently to unstick the sailplane. Hold the sailplane in horizontal flight at a height of 3 ft (1 m) until the towing airplane starts to climb. The take-off with cross wind is different from the normal take-off. It is necessary to bank the wing into the wind (in proportion to the wind speed) and to unstick the sailplane at a higher speed. The tow rope should be attached to the front hook only.

Note: Before take-off close the ventilation in order that dust and impurities do not get into the cockpit. The ventilation can be opened during at climb.

2. Winch-launching

CAUTION: Use either side hooks or lower hook (depending on which hook is installed).

WARNING: NEVER USE FRONT HOOK FOR WINCH-LAUNCHING.

The winch launching is entirely conventional. Set the elevator trim tab control to the neutral position. The recommended speed for winch launching is 43 - 54 KIAS (80 - 100 km/h IAS). Do not retract the landing gear when performing the traffic pattern.

3. Aerotow

a) Climb

Retract and lock the landing gear (by pulling the handle in your direction) when above a minimum safe height of 66 ft and the minimum speed of 54 KIAS (100 km/h IAS) is reached. Trim the sailplane for the climb speed. The sailplane angle of attack is fairly high when the climb speed is low and the view from cockpit is reduced considerably. Therefore it is recommended that the towing aircraft to keep a climbing speed of 54 - 70 KIAS (100 - 130 km/h IAS) .

(Cont.)



The pilot should avoid overcontrolling.

Principles of aerotow are the same as for other sailplanes.

b) Level flight

The maximum speed for aerotow is 81 KIAS (150 km/h IAS). It is necessary to trim the sailplane to reduce control forces and to decrease pilot fatigue during longer flights on tow. It is necessary to realize that control sensitivity increases with flight speed.

c) Descending

A satisfactory rate of descent 390 - 590 ft/min (2 - 3 m/s) can be obtained when the towing aircraft maintains an airspeed at least of 54 KIAS (100 km/h IAS) .

4.4.2 FLIGHT

1. Turns and circling

The sailplane is very manoeuvrable and controllable and its behaviour is very good in turns with angles bank up to 60° .

2. Side slipping

The piloting technique of the side slipping is entirely conventional. The angle of bank of the sailplane should be between 10° and 20° . The side slip is not very effective mean of losing height in this sailplane. As, the rate of descent may be effectively increased by the use of the air brakes. If a constant airspeed is to be maintained during a side slip, the angle of pitch must be constant. The air speed indicator is unreliable during slip manoeuvres.

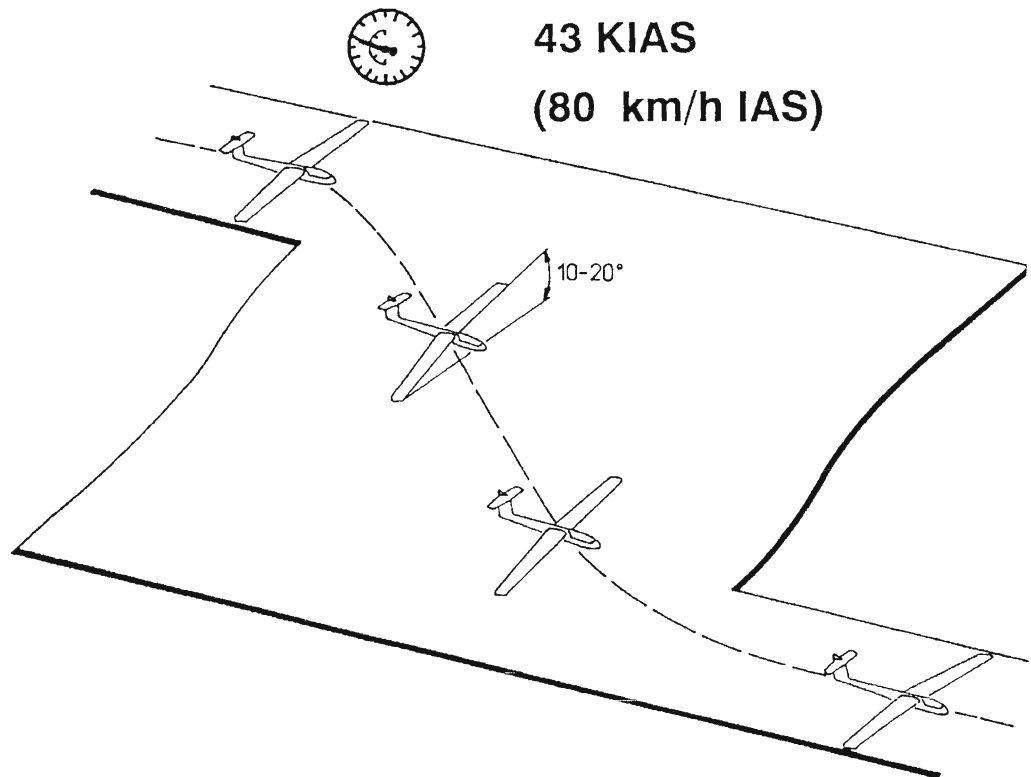

FIG. 4 - 2



3. Stalls

Slow and continuous pulling aft on the control stick causes the sailplane to stall. Ailerons and rudder should be used to control bank, if any. Pre-stall warning starts (at the speed of about 5% higher than the stalling speed), in the form of buffeting of the rudder pedals and of all front fuselage section. When stalled, the sailplane settles with a gentle pitching. Move the control stick forward and start the stall recovery.

CAUTION: Before stalling and spinning the following procedures must be done:

Trim:	neutral
Air brakes:	retracted and secured
Cockpit canopy	locked and secured
Ventilation	shut
Rudder pedals:	properly adjusted to allow full deflections
Safety belts:	fastened and tight
Loose objects:	removed or secured

4. High Altitude Flight

Operation above 13, 780 (4,200 m) feet has not been demonstrated by the manufacturer. A sailplane placard provides calculated maximum (VNE) airspeeds above a pressure altitude of 13, 780 (4,200 m) feet for information only. High altitude flight should be conducted in accordance with any applicable operating rules.



4.4.3 APPROACH

The following approach speeds are recommended.

Descent	Air brakes	Approach speeds
Normal	retracted	41-46 KIAS (75 - 85 km/h IAS)
	extended	43-51 KIAS (80 - 95 km/h IAS)
Steeper	extended	51-60 KIAS (95 - 110 km/h IAS)

Anticipate mild sailplane ballooning when using higher approach speeds.

4.4.4 LANDING

Landing on the airport

The landing manoeuvre is entirely conventional. Use small elevator inputs at the flare. The sailplane should touch down with the landing gear first and then with the tail wheel if landed correctly (to reduce shock to the tail wheel on ground contact). Do not flare prematurely in order to prevent the sailplane from dropping from a higher height.

Off-field landing

It is recommended to land with the landing gear retracted if landing on a soft ground.

Note: In this case extend the wheel before the next flight.

Post flight

The following operations must be recorded in the sailplane log book as they occur:

- (1) Flight time with wing tip extensions installed.
- (2) Number of winch and aerotow launches by type.
- (3) Flight time during acrobatic manoeuvres.



4.4.5 USE OF AIR BRAKES

It is recommended to use the air brakes in following cases :

1. To reduce landing especially roll on rough ground.
2. To increase accuracy of the landing manoeuvre.

Note: In case of using air brakes during landing, it is necessary to maintain an approach speed of about 5 kts (10 km/h IAS) higher, because the stall speed with fully opened air brakes is about 3-4 kts(5 - 7 km/h IAS) higher.

3. To avoid exceeding the never exceed speed (v_{NE}) during unusual attitude recoveries (for example during aerobatics).

It is recommended to use the air brakes in any case when the sailplane starts to increase the speed and the pilot is uncertain of his orientation or how to manage the situation. Configuration with " air brakes extended" will ensure that v_{NE} is not exceeded. Use of air brakes will enhance the safety and makes handling easier because the extended air brakes tend to stabilize the sailplane.

The control lever should be held firmly when operating the air brakes to ensure smooth deployment and retraction.



4.4.6 BASIC AEROBATICS

The L 23 SUPER-BLANIK sailplane is able to perform the listed approved aerobatic manoeuvres. The rate of acceleration of this sailplane is high, so great care must be taken not to exceed limitations given in Sections 2.2, 2.6 and 2.7.

Instruction guidelines for performing approved aerobatic manoeuvres are given on pages 13 to 19 of this Section.

WARNING: ONLY MANOEUVRES WITH POSITIVE G LOAD FACTORS ARE APPROVED.

(Cont.)

1. Loop

Enter a moderate dive with slight forward movement of the control stick to gain a speed of 86 KIAS (160 km/h IAS) when flying solo or 97 KIAS (180 km/h IAS) when flying dual. Raise the nose of the sailplane by slight backward movement of the control stick, taking care not to apply excessive "g" forces, and maintain this rate of backward stick movement throughout the first half of the loop, but do not use more than about 60 % of the control stick full deflection. The load factor must drop in the inverted position. After passing the inverted position the speed will increase and the control stick must be eased forward gradually until the sailplane is flying level again. Before and during this manoeuvre rudder should be used to prevent yaw and ailerons used to keep the wings level. Maintain precise directional control for proper completion.

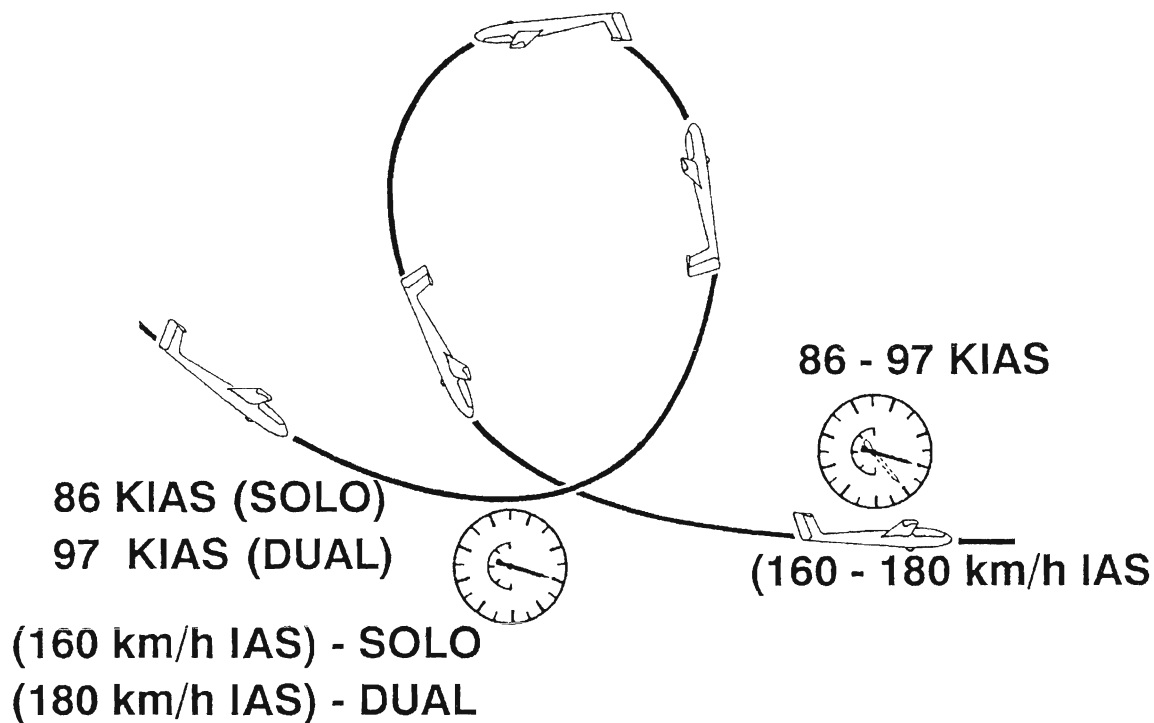

FIG. 4 - 3

(Cont.)

2. Stall turn

This manoeuvre should be begun at the speed of 92 KIAS (170 km/h IAS) when flying solo or 97 KIAS (180 km/h IAS) when flying dual. Pull the control stick gently backward to bring the nose to a position of about 60° to 70° above the horizon. Ease the control stick forward slightly to maintain this attitude. As the speed falls to 70 - 76 KIAS (130 - 140 km/h IAS), start to apply rudder slowly in the required direction of turn. As the force on the rudder decreases, gradually apply full rudder.

Full deflection of the rudder should be reached when the sailplane heads about 45° in the direction of turn. The ailerons should be used against the direction of turn as necessary to prevent the sailplane rolling to the inverted position. As the nose approaches the reciprocal heading, neutralize the rudder, keep the wings level by use of the ailerons, and ease out of the resulting dive, taking care not to apply excessive "g".

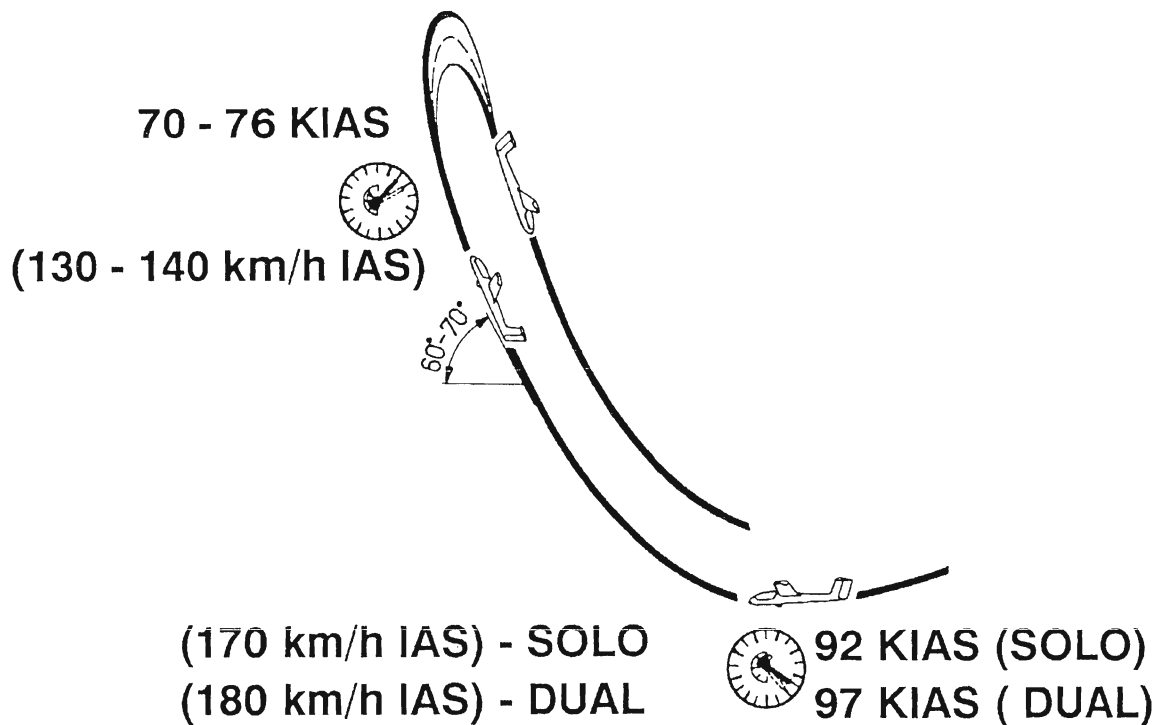

FIG. 4 - 4

(Cont.)

3. Lazy eight

Move the control stick slowly forward to attain the entry speed of 97 KIAS (180 km/h IAS) solo or dual. Perform the steep turn to the selected side, smoothly pulling the control stick with simultaneous coordinated use of ailerons and rudder.

At a speed of 54 KIAS (100 km/h IAS) transition the sailplane to a descent and after reaching a speed of 97 KIAS (180 km/h IAS) perform the steep turn to the opposite side, smoothly pulling the control stick with simultaneous coordinated use of ailerons and rudder.

The flight path intersects at the lowest point of the manoeuvre.

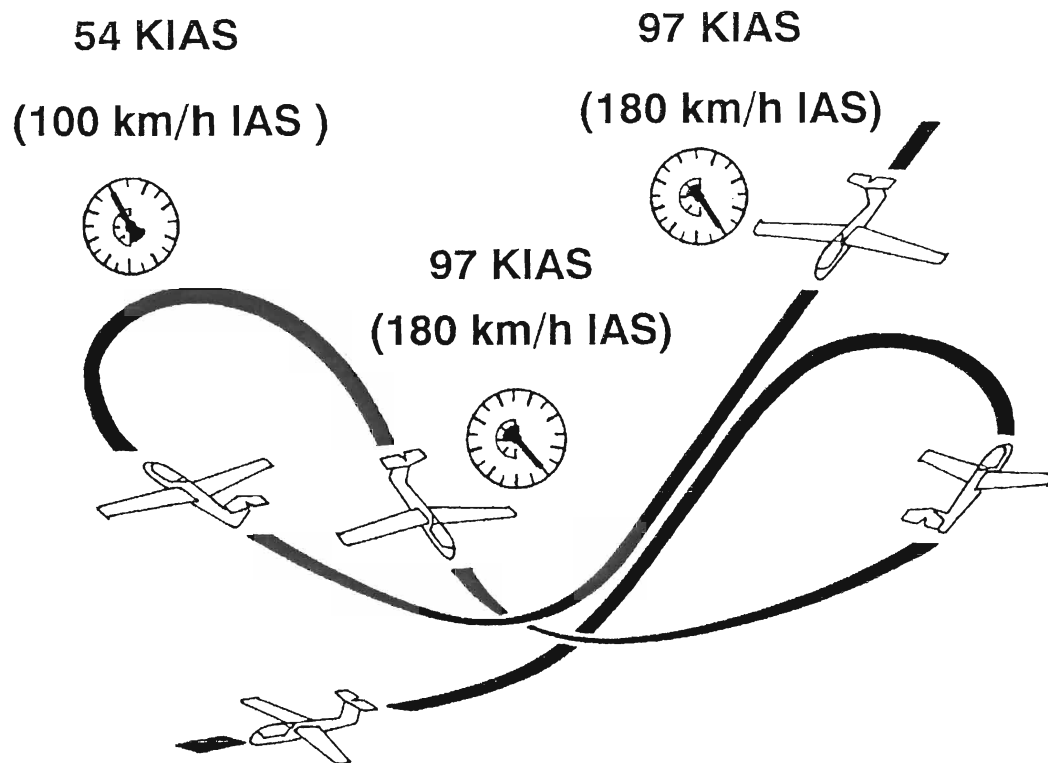

FIG. 4 - 5



4. Spin

The sailplane performs the spin without any tendency to enter a flat spin at all operating centre of gravity positions. The sailplane has the tendency to recover from the spin by itself, when at the maximum flight weight and the forward centre of gravity. Entering the spin is entirely conventional. Pull the control stick slowly back to approach the stall, use the full deflection of the rudder at the stall speed of approximately 32 KIAS (60 km/h IAS) (Fig. 4-3) and maintain full aft deflection of the control stick. Initiate recovery from the spin by applying full opposite deflection of the rudder. When the sailplane stops the rotation, neutralize the rudder and simultaneously ease the control stick forward. Recover the sailplane from the dive in the usual way. The attitude during the spin is 60° to 70° nose down and the loss of height in one turn is approximately 260 ft (80 m) when flying solo and 390 ft (120 m) when flying dual. The time of one revolution of the spin is approximately 3.5 secs.

Caution: 1. **Before spinning accomplish the procedures given in the Flight Manual, Section 4, paragraph 3.**

2. **IAS error.**

The airspeed indications become erroneous at large yaw angles, because the static vents on the sides of the fuselage are by-passed asymmetrically.

3. **When the spin is performed as an aerobatic manoeuvre, it is possible to maintain the spin by applying aileron in the direction of the rotation.**

Stop the spin rotation by applying full opposite rudder and neutralize the ailerons. When the sailplane stops the rotation, neutralize the rudder and ease the control stick forward. Pull-out from the dive using standard procedure.

Note: Airspeed indications well above the stall speed during a spin may indicate a spiral dive rather than a spin.

(Cont.)

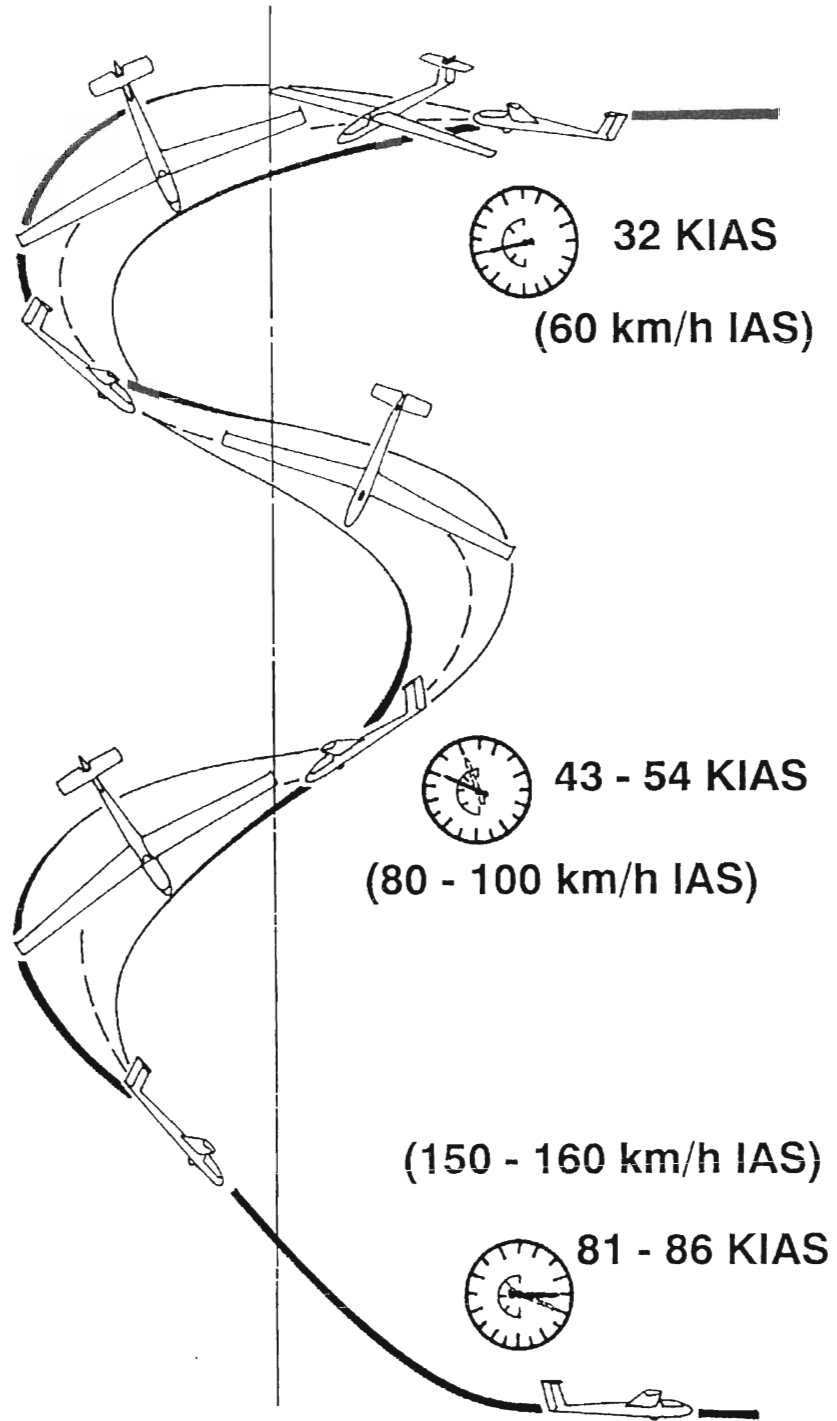

FIG. 4 - 6

5.Chandelle (climbing)

Move the control stick slowly forward to attain the entry speed of 97 to 103 KIAS (180 to 190 km/h IAS) solo or dual.

Transition the sailplane to a steep climb at an angle of approximately 45° above the horizon (do not increase the angle).

At a speed of 76 KIAS (140 km/h IAS), apply the rudder to the selected side of the turn and by coordinated positive use of the ailerons make a transition to gliding flight in the opposite direction at a minimum speed of 43 KIAS (80 km/h IAS).

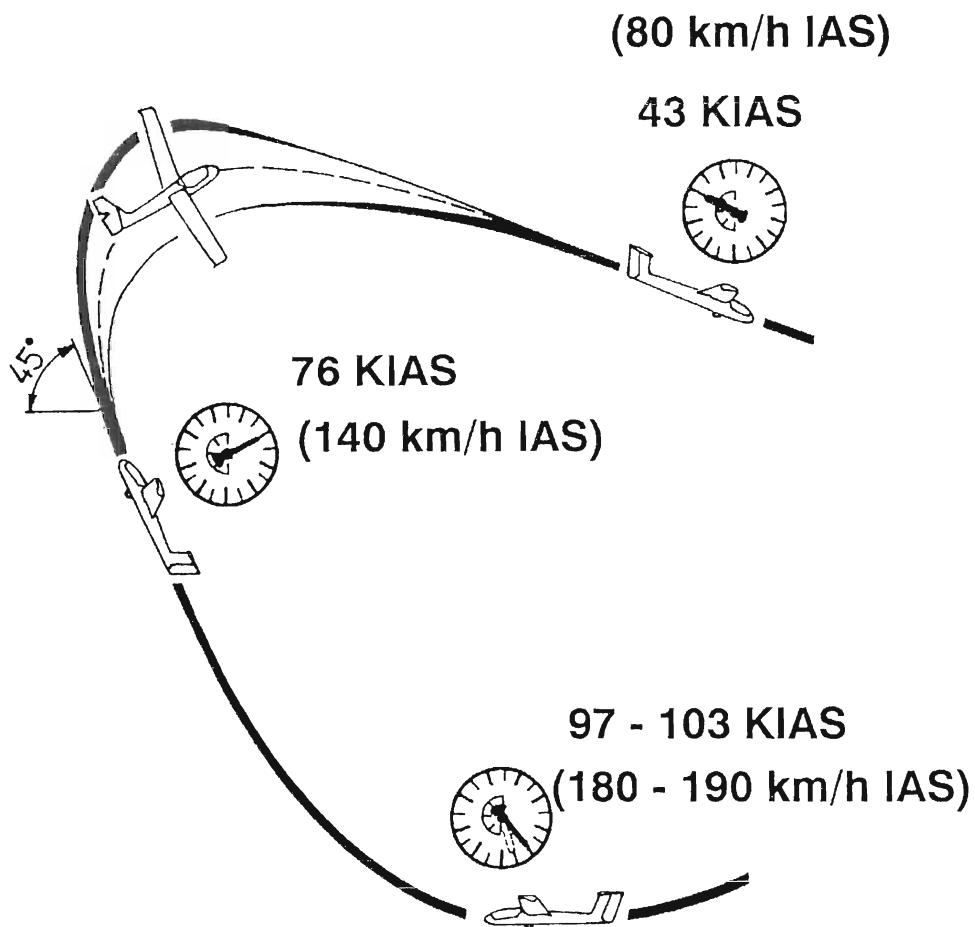

FIG. 4 - 7

(Cont.)

6. Steep turn

To perform this manoeuvre keep the entry speed of 92 KIAS (170 km/h IAS) when flying solo or 97 KIAS (180 km/h IAS) when flying dual. Enter the climb simultaneously with a bank of approx. 45°. After turning 150° start a transition to a glide angle such that the manoeuvre will be finished in the opposite direction with the speed not decreasing below 43 KIAS (80 km/h IAS).

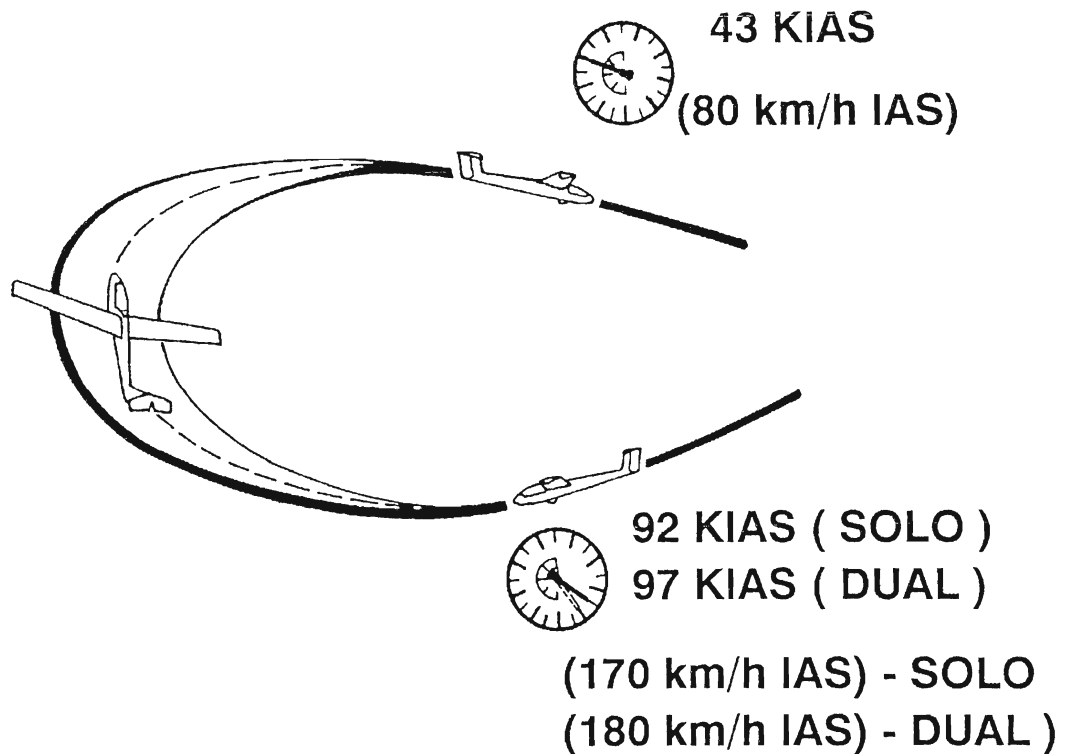

FIG. 4 - 8



SECTION 5

Performance

CONTENTS

- 5.1 Introduction
- 5.2 Approved data
 - 5.2.1 Airspeed system calibration
 - 5.2.2 Stall speeds
- 5.3 Additional information
 - 5.3.1 Flight polar

5.1 INTRODUCTION

Section 5 provides approved data for airspeed calibration and stall speeds. Other non-approved information is provided.

5.2 APPROVED DATA

5.2.1 AIRSPEED INDICATOR SYSTEM CALIBRATION.
(Assumes zero instrument error)

It is valid for maximum weight of the sailplane.

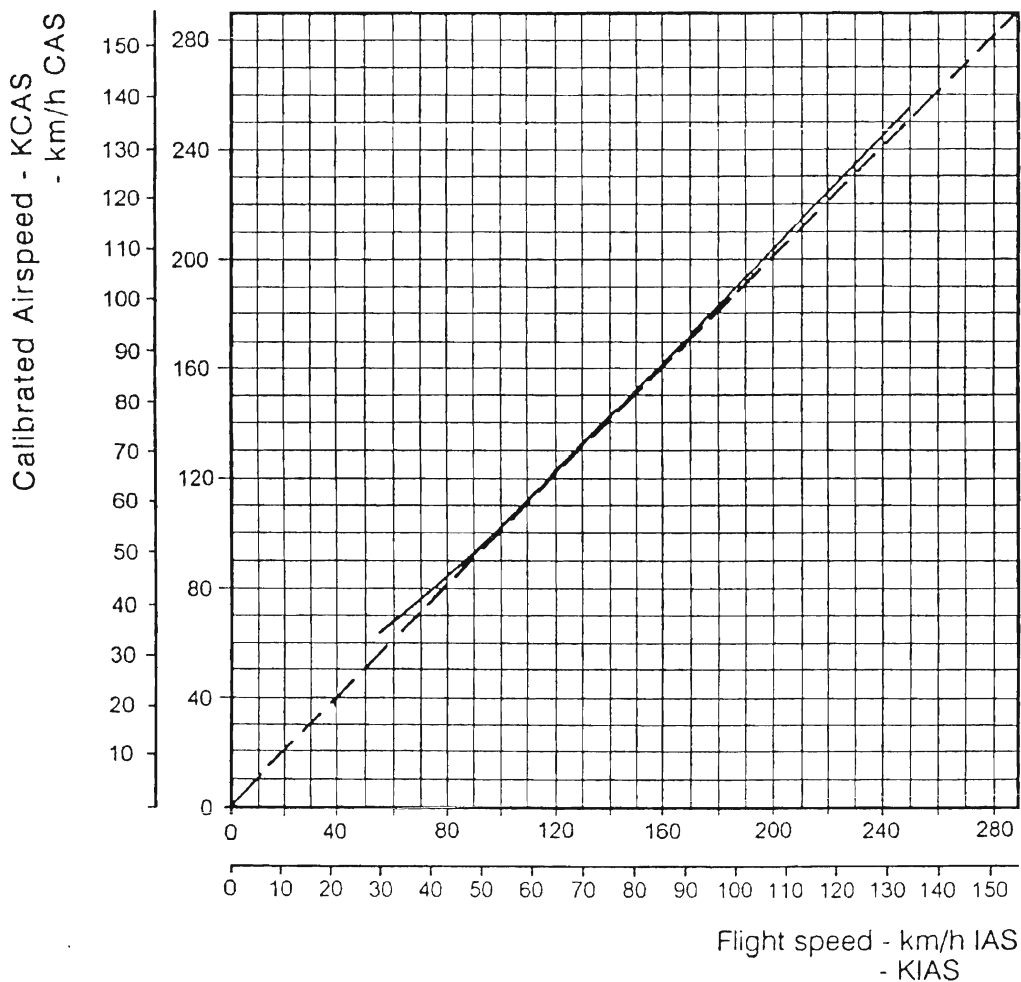

FIG. 5 - 1



5.2.2 STALL SPEEDS (unaccelerated)

The broken line is valid only when using the wing tip extensions.

Note: The stall warning speed is about 5 % higher than stall speed for all configurations.

Stall speed for forward c.g. position

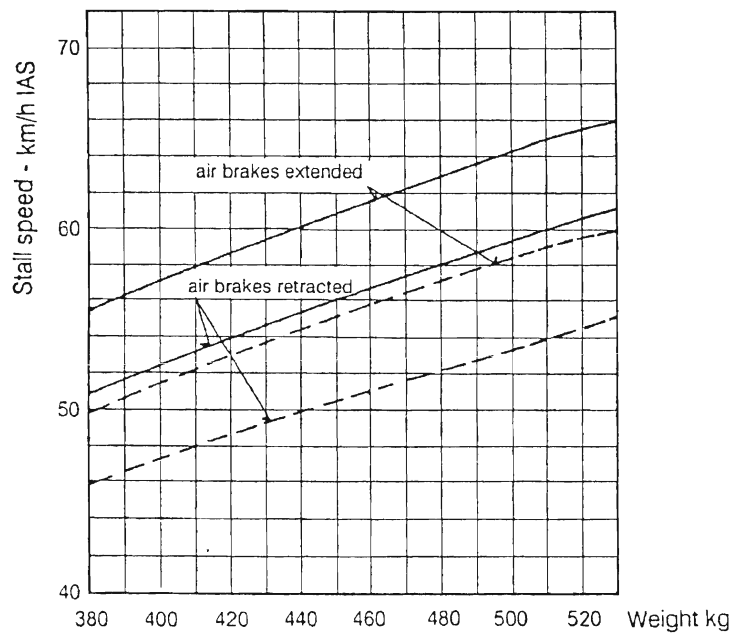
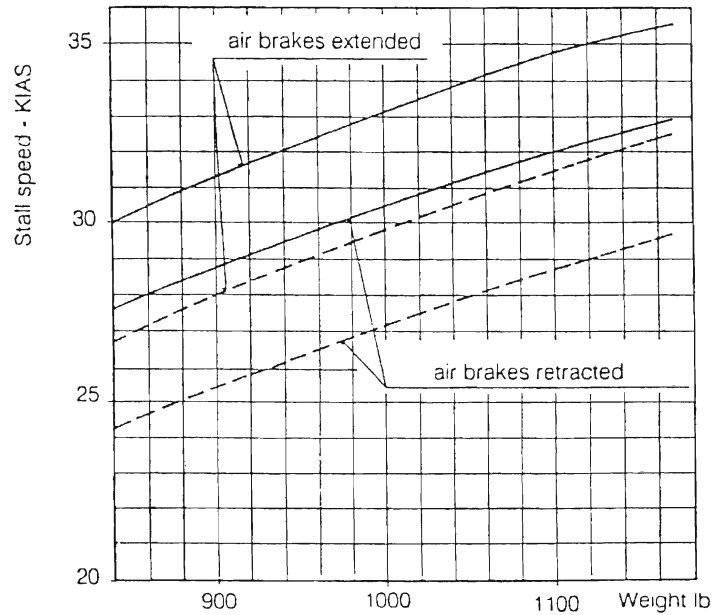

FIG. 5 - 2



5.3 ADDITIONAL INFORMATION

5.3.1 FLIGHT POLAR

5.3.1.1 FLIGHT SPEED POLAR

Maximum flight weight of 882 lb and 1168 lb.
Air brakes retracted, landing gear retracted.

Airspeed with the angle of descent of 45° 124 KIAS

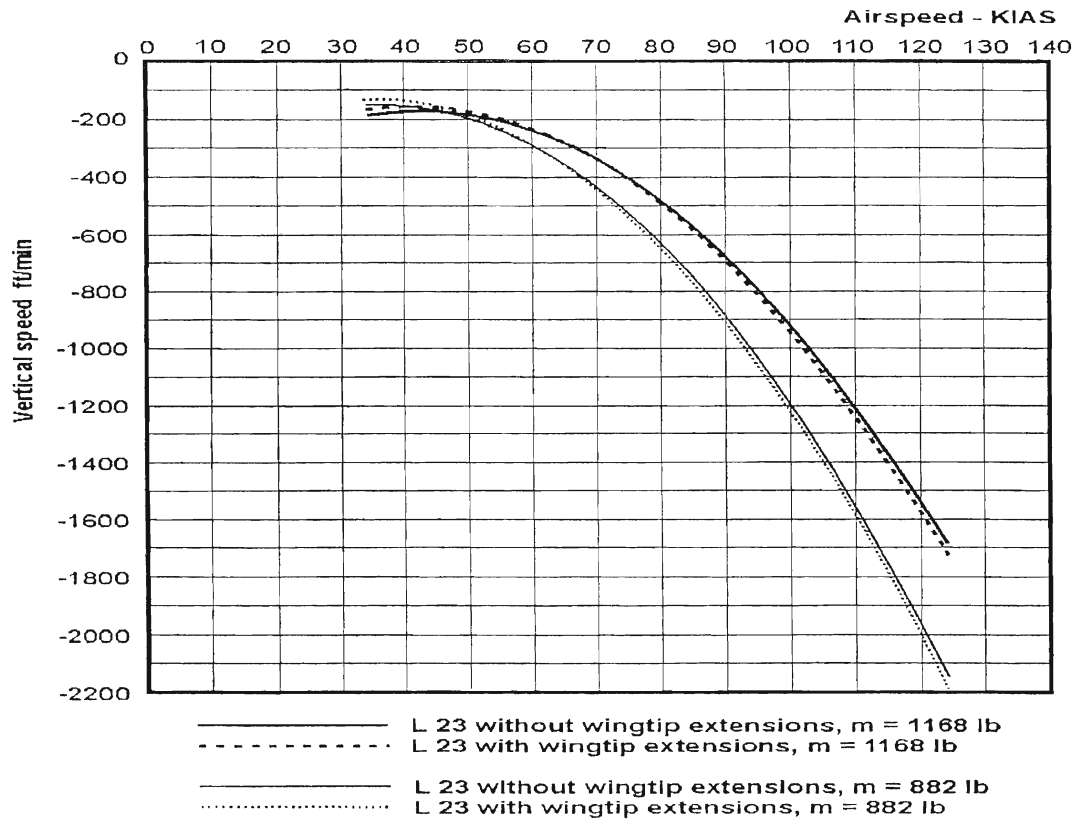

FIG. 5 - 3



5.3.1.2 FLIGHT SPEED POLAR

Maximum flight weight of 400 kg and 530 kg.
Air brakes retracted, landing gear retracted.

Airspeed with the angle of descent of 45°229 km/h IAS

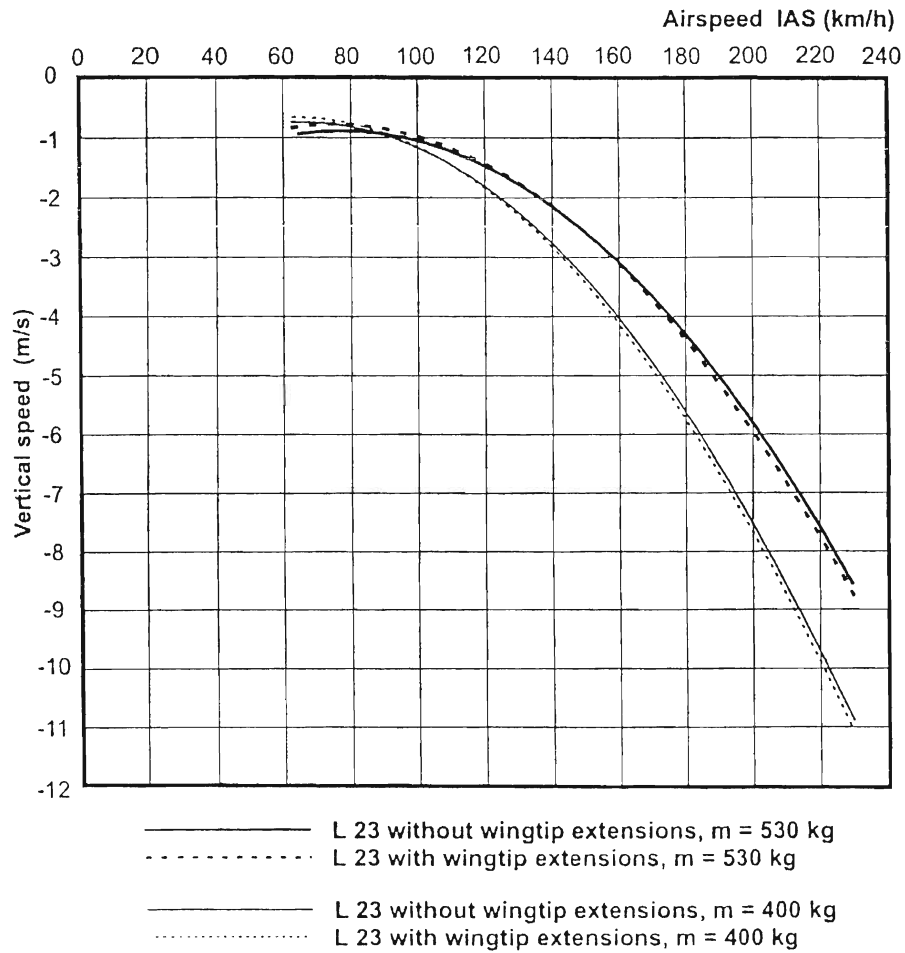

FIG. 5 - 3



SECTION 6

Weight and balance

CONTENTS

- 6.1 Introduction
- 6.2 Weight and balance record
- 6.3 Basic empty weight and moment
- 6.4 Balance chart
- 6.5 Balance record
- 6.6 Equipment list



6.1 INTRODUCTION

Section 6 includes basic empty weight and moment of the sailplane with standard equipment and the equipment list (standard and optional equipment). Procedures for determining the weight and centre of gravity position are explained by an example calculation.

6.2 WEIGHT AND BALANCE RECORD

Weight and balance record providing information for calculating centre of gravity position is given in the Maintenance Manual of the L 23 SUPER - BLANIK Sailplane, chapter 8.

6.3 BASIC EMPTY WEIGHT AND MOMENT

Basic empty weight 683 lb(310 kg) ± 2%
(with the installed wing tip extensions) . . . 695 lb(315 kg) ± 2%

Moment to the reference plane 17,923.1 in-lb(206.5 kgm)

(see weight and balance record).

The reference datum is located 93.6 in aft of the sailplane nose.

6.4 BALANCE CHART (FIG. 6-1)

1. Balance chart description

The varying load scales are in the upper part of the page. The separate scales are plotted in the middle part of the page. The chart of the centre-of-gravity position vs. sailplane weight is given in the bottom part of the page. The region of the allowable centre of gravity range is the slanted shape in the chart and it refers to all flight conditions.

(Cont.)



2. Directions for the balance chart use

See FIG.6-1 on Page 6-4, Line 0.

- . Make a dot on the Empty Sailplane Center of Gravity Range corresponding with the value shown on the Balance Record on page 6 - 5. When the wing tip extensions are used, move the center of gravity of the empty sailplane 1% MAC in aft direction. Draw a vertical down to Line 1. The intersection of the vertical and Line 1 is Point A.
- . Next, use Scale 1 at the top of the chart. Measure the distance from 0 on that scale to a number corresponding with the weight of the front pilot + parachute + ballast seat (if used). Transfer this distance from Point A to the left, draw a vertical, and mark the intersection with Line 2 as Point B.
- . Next, use Scale 2. Measure the distance from 0 on that scale to a number corresponding with the weight of the rear pilot + parachute. Transfer this distance from Point B to the left, draw a vertical, and mark the intersection with Line 3 as Point C.
- . Next, use Scale 3 for any changes in the front instrument panel. Measure the distance from 0 on that scale to a number corresponding with the weight of any instrument added or removed. Transfer this distance from Point C to the left (if an instrument is added), to the right (if removed). Draw a vertical, and mark the intersection with Line 4 as Point D.
- . Next, use Scale 4 for any changes in the rear instrument panel in the same fashion as in the previous paragraph. That is how you arrive at point E. Draw a vertical on down to the lower part of the chart.
- . Now, use the weight scale on the lower left part of the balance chart. Mark the sum of all weights: Empty sailplane + front pilot + parachute + ballast seat + rear pilot + parachute + instrument changes + baggage.
- . Draw a horizontal line from the mark to the right. The center of gravity position is at the intersection of this horizontal line with the vertical from Point E.
- . If this intersection is inside the slanted shape, the glider is loaded correctly. If the intersection is outside, the glider has to be reloaded.

Note: The baggage weight is to include any battery, oxygen bottle, water bottle etc. Items in the baggage compartment have no influence on the centre of gravity position, but they must be included to the sum of all the weights.

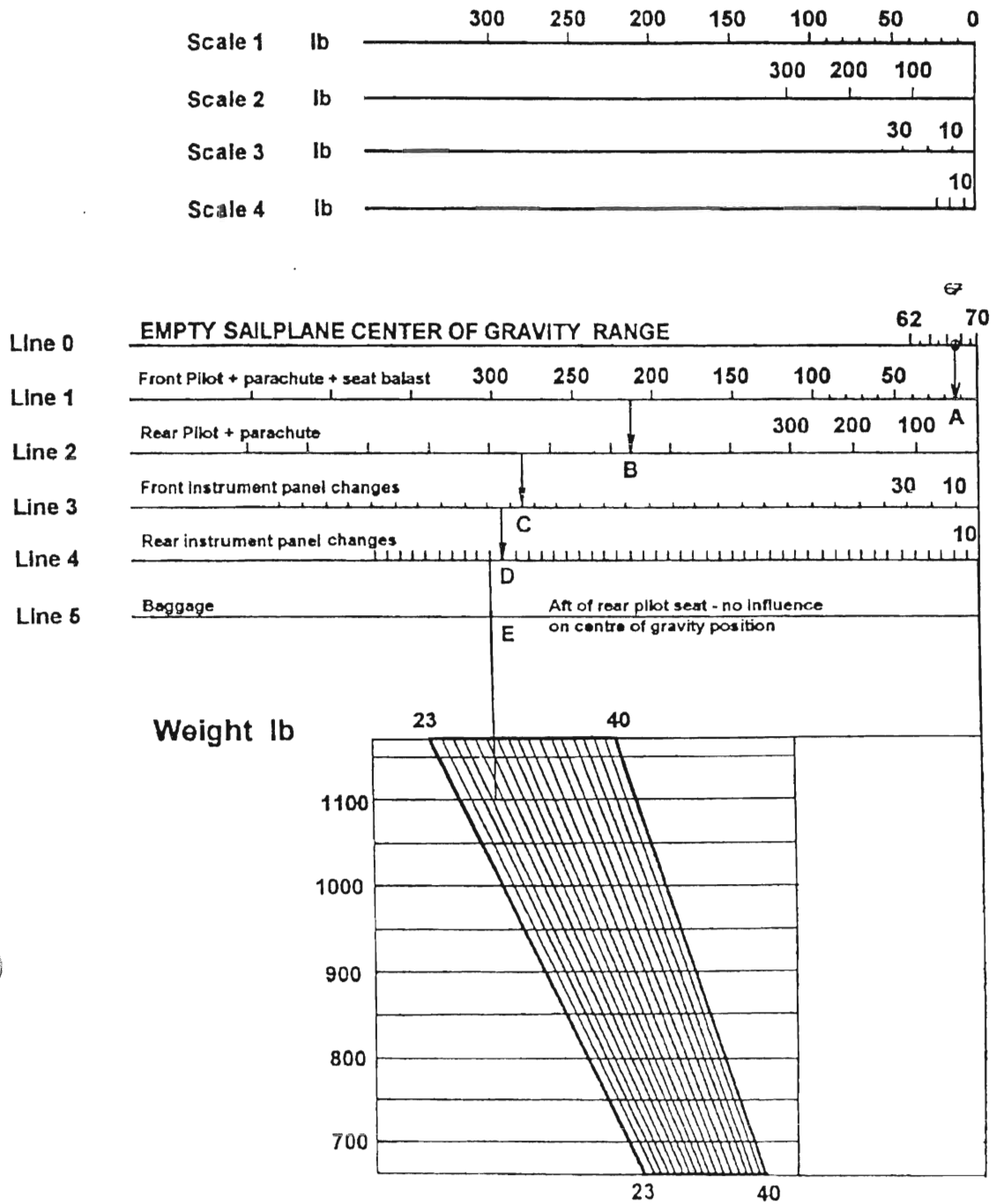

FIG. 6 - 1



6.5 BALANCE RECORD

No.	Empty weight lb	c/g pos. % MAC	Permitted crew + passenger weight (lb) with :												Approved	
			Max. baggage (22 lb)				Half baggage (11 lb)				No baggage (0 lb)				Date	Signed
			Front seat		Rear seat		Front seat		Rear seat		Front seat		Rear seat			
			Max.	Min.	Max.	Min.	Max.	Min.	Max.	Min.	Max.	Min.	Max.	Min.		
1.	726.2	68.1	287	170	/	/	287	170	/	/	287	158	/	/	5.3 02	
2.	726.2	68.1	287	-	133	-	287	-	144	-	287	-	155	-	5.3 02	
3.	726.2	68.1	133	-	287	-	144	-	287	-	155	-	287	-	5.3 02	

1. Single seat

2. Tandem seater-max front pilot

3. Tandem seater-max rear pilot



6.6 EQUIPMENT LIST

Standard (S) items must be installed for all operations. Optional (O) items are available for installation. Installed items for each sailplane equipment list will be marked with an "X" and included in the Empty Weight/c.g. pos of the Balance Record.

	S	O	Subject	Type	Mass lb (kg)	Arm from the reference plane (rib No. 1) ft (mm)	Date of installation
1	X		Altimeter	UI5934P-3 front instr.panel rear instr.panel	0.90 (0.41)	- 5.82 (-1774) - 1.81 (-551)	
2	X		Airspeed indicator	LUN 1106.15-8 front instr.panel rear instr.panel	0.88 (0.4)	- 5.83(-1777) - 1.82(-555)	
3		X	Electric turn-and-bank/side indicator	LUN 1211.1 front instr.panel rear instr.panel	0.79 (0.36)	- 5.83(-1777) - 1.82(-555)	
4		X	Vertical speed indicator \pm 1000 ft/min or Vertical speed indicator \pm 10 knots	LUN 1141.02 front instr.panel rear instr.panel or LUN 1141.04 front instr.panel rear instr.panel	1.06 (0.48) 1.06 (0.48)	- 5.87(-1789) - 1.87(-570) - 5.87(-1789) - 1.87(-570)	
5		X	Vertical speed indicator \pm 6000 ft/min or Vertical speed indicator \pm 60 knots	LUN 1147.12-8 front instr.panel or LUN 1147.23-8 front instr.panel	1.1 (0.5) 1.1 (0.5)	- 5.802(-1768) - 5.802(-1768)	

(Cont.)



	S	O	Subject	Type	Mass lb (kg)	Arm from the reference plane (rib No. 1) ft (mm)	Date of instalation
6		X	Magnetic compass	LUN 1221.1-8 front instr.panel rear instr.panel	0.23 (0.105)	- 5.79(-1765) - 1.79(-546)	
7		X	Accelerometer	AM-10 front instr. panel	0.55 (0.25)	- 5.51(-1679)	
8		X	Radio station				

Optional (O) Items 3, 4, 5, 6, 7 as applicable is required for pilot's station for cloud flying operations.

	S	O	Subject	Type	Mass lb (kg)	Arm from the reference plane (rib No. 1) ft (mm)	Date of instalation
9							
10							
11							
12							
13							
14							
15							
16							



SECTION 7

Sailplane and systems description

CONTENTS

- 7.1 Introduction
- 7.2 Sailplane description
- 7.3 Front seat ballast
- 7.4 Front cockpit
- 7.5 Rear cockpit

7.1 INTRODUCTION

The description and operation of the sailplane and its systems are given in the Maintenance Manual of the L 23 SUPER - BLANIK Sailplane.

7.2 SAILPLANE DESCRIPTION

The L 23 SUPER - BLANIK sailplane is a cantilever, high-wing, two-seat glider of all-metal structure. The rudder, elevator and ailerons are fabric covered. In the forward section part of the fuselage there are front and rear cockpits. Both cockpits are covered with a two-part canopy which can be jettisoned in flight. Both cockpits are equipped with all sailplane flight control including flight and navigation instrument panels. The sailplane is equipped with tow hooks either for winch or aero-tow take-off.

Wings including ailerons and air brakes, are attached to the fuselage at six suspension points (three on each side). There is a possibility of using the wing tip extensions which enlarge the wing span from the 81st series. They may be connected to the standard wing instead of the laminated wing tips. The vertical stabilizer is permanently fixed to the rear fuselage section. The horizontal stabilizer is fastened by hinges on the top of the vertical stabilizer.

Elevator and aileron controls are actuated by control push rods and control cables, the rudder control is pedal-operated also by control push rods and control cables. Air brakes are controlled by control levers. The elevator trim tab is controlled by the control lever.

The sailplane is equipped with the main landing gear and the tail landing gear. The main landing gear is mechanically semi-retractable with an oleo-pneumatic shock-absorber and a mechanical brake. The tail landing gear is equipped with a wheel and shock-absorber. Cockpits are ventilated by cold air tapped from the nose part of the fuselage. The baggage compartment is behind the rear cockpit. Both cockpits are upholstered.

7.3 FRONT SEAT BALLAST

A. Seat installation, Fig. 7-1

1. Disassemble and remove the seat from the front cockpit.
2. Put the seat with ballast into the free space and insert stirrups (pos. 2) in the rear part of the seat into the chamber on the rest suspender.
3. Move the levers on the seat sides upwards (pawls will shift in the seat face) and fold the seat (pos. 1) to the floor.
4. Move the levers downwards, the pawls will shift out and they must shift in the hole on the floor frame (if the pawls do not shift in the holes, move the seat to both sides to enable shifting the pawls in the holes).

B.Seat removal

Removal is carried out in a reverse order to installation.

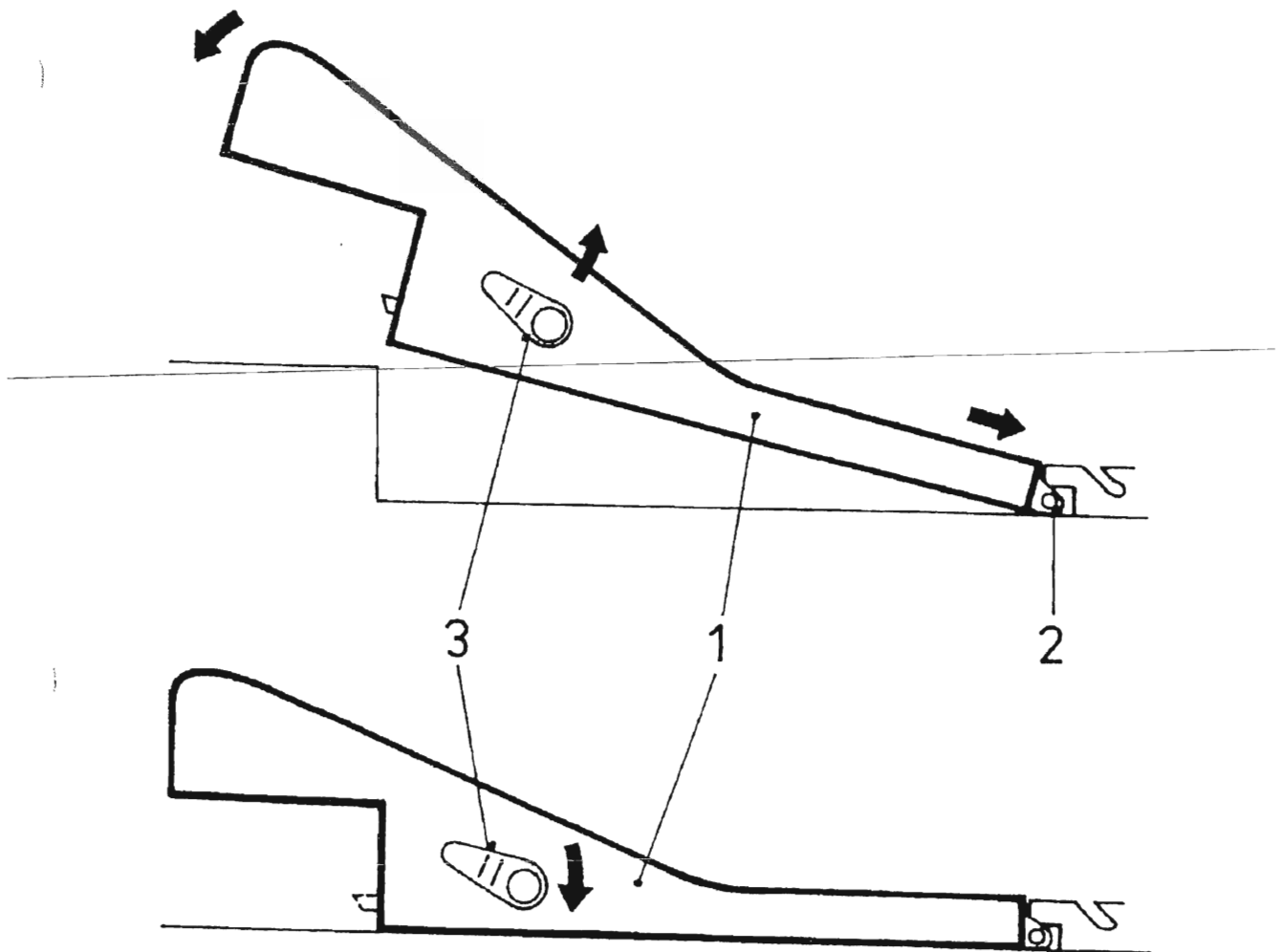

FIG. 7 - 1

7.4 FRONT COCKPIT - STANDARD

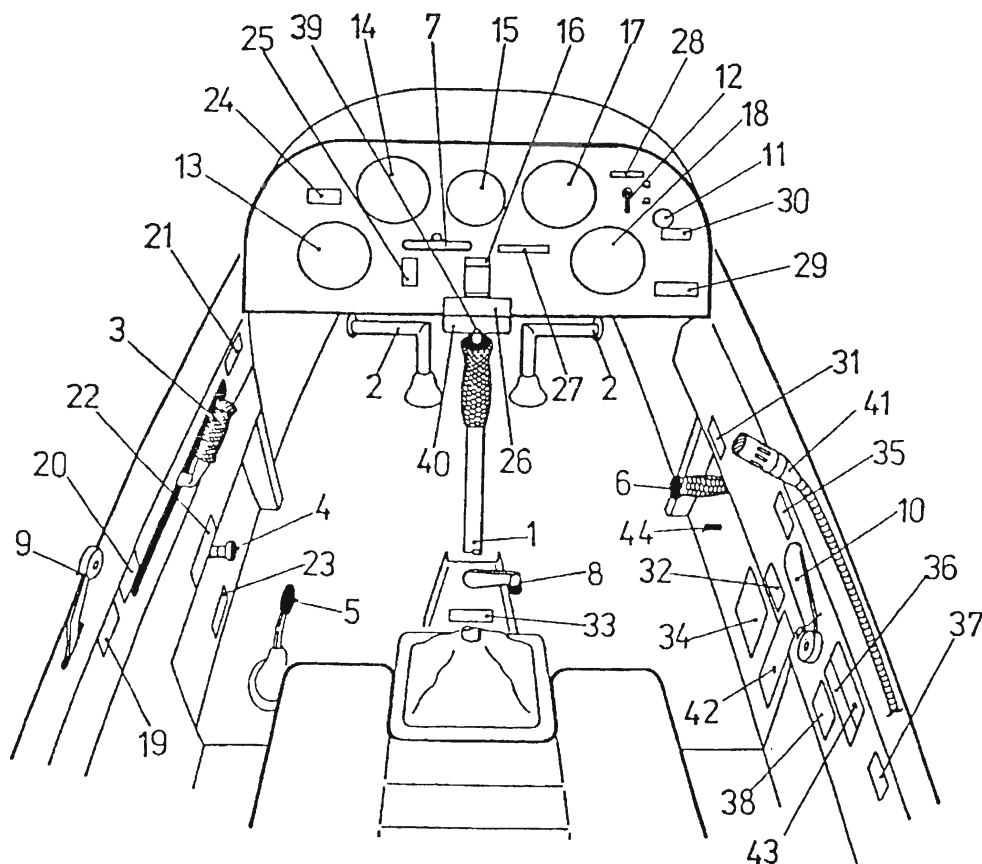

Fig. 7-2

- (1)Control column, (2)Rudder pedals, (3)Airbrake handle, (4)Elevator trim handle, (5)Wheel brake handle, (6)Landing gear handle, (7)Rope release mechanism, (8)Rudder pedals adjustment, (9)Cockpit hood opening handle, (10)Handle of canopy jettison, (11)Air vent pull rod with handle, (12)Turn-and-bank indicator switch, (13)Altimeter, (14)Airspeed indicator, (15)Turn-and-bank indicator, (16)Compass, (17) and (18)Vertical speed indicators, (19)Label "Canopy lift off" , (20)Label "Airbrakes extended", (21)Label "Airbrakes retracted", (22)Label "Elevator trim control", (23) Label "Wheel brake", (24)Label "No smoking", (25)Label "Tow release", (26)Label "Max. airspeeds", (27)Identification number, (28)Label "TURN-AND-BANK INDICATOR", (29)Label "Manoeuvres with wing tip extensions forbidden", (30)Label "Air vent", (31)Label "Landing gear extended", (32)Label "Landing gear retracted", (33)Label "Adjustment of pedals", (34)Label "Max. pilot weight", (35)Label "Canopy jettison", (36)Label "Operating limitations", (37)Label "Seat position", (38)Label "Center of gravity", (39)Radio control button, (40)Battery for turn-and-bank indicator, (41)Microphone, (42)Deviation chart, (43)Label "Max. allowable speed vs altitude", (44)Positional pin of landing gear opened and locked position (the landing gear handle must be located in front of the positional pin in flight direction)

7.5 REAR COCKPIT - STANDARD

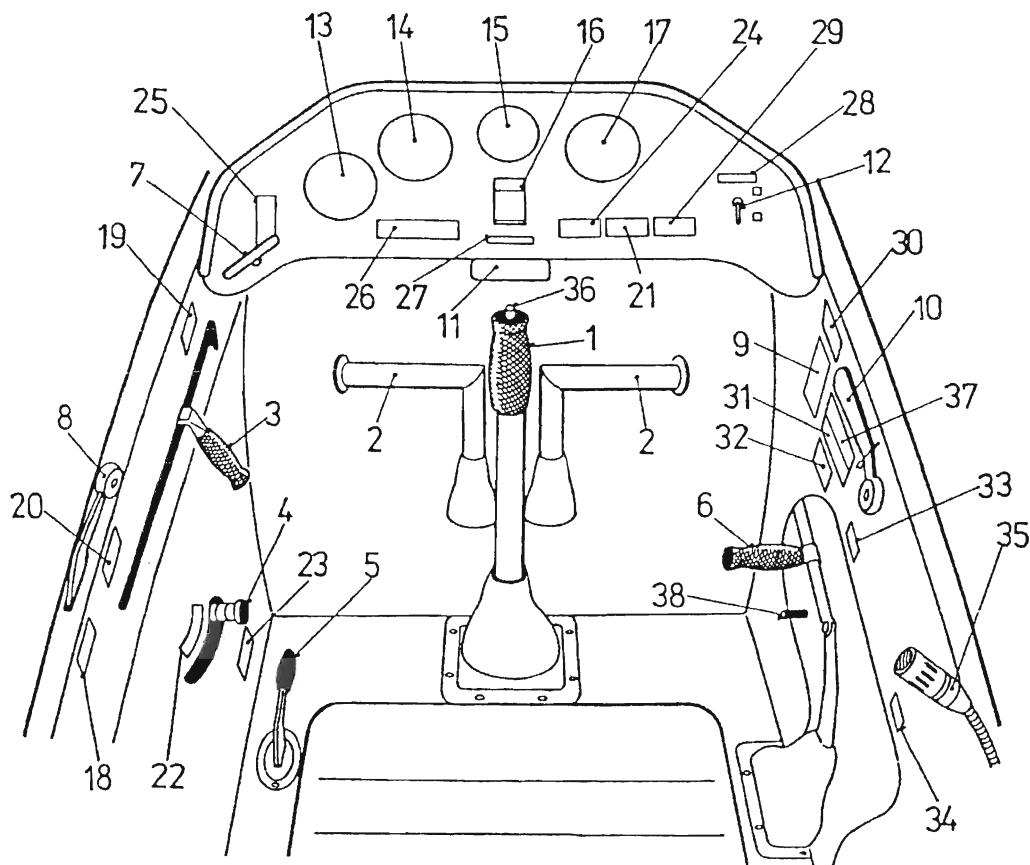

Fig. 7-3

- (1)Control column, (2)Rudder pedals, (3)Airbrake handle, (4)Elevator trim handle, (5)Wheel brake handle, (6)Landing gear handle, (7)Rope release mechanism, (8)Cockpit hood opening handle, (9)Deviation chart, (10)Handle of canopy jettison, (11)Battery for turn-and-bank indicator, (12)Turn-and-bank indicator switch, (13)Altimeter, (14)Airspeed indicator, (15)Turn-and-bank indicator, (16)Compass, (17)Vertical speed indicator, (18)Label "Airbrakes extended", (19)Label "Airbrakes retracted", (20)Label "Canopy lift off", (21)Label "Max. airspeeds", (22)Label "Elevator trim control", (23)Label "Wheel brake", (24)Label "No smoking", (25)Label "Tow release", (26)Label "Max. airspeeds", (27)Identification number, (28)Label "TURN-AND-BANK INDICATOR", (29)Label "Manoeuvres with wing tip extensions forbidden", (30)Label "Canopy jettison", (31)Label "Operating limitations", (32)Label "Center of gravity", (33)Label "Landing gear extended", (34)Label "Landing gear retracted", (35)Microphone, (36)Radio control button, (37)Label "Max. allowable speed vs altitude", (38)Positional pin of landing gear opened and locked position (the landing gear handle must be located in front of the positional pin in flight direction)



SECTION 8

Sailplane handling, care and maintenance

CONTENTS

- 8.1 Introduction
- 8.2 Sailplane inspection period



8.1 INTRODUCTION

Procedures recommended by the manufacturer for proper ground handling, servicing and maintenance, which must be followed if the sailplane is to retain new-plane performance and dependability, are given in the Maintenance Manual of the L 23 SUPER - BLANIK Sailplane.

8.2 SAILPLANE INSPECTION PERIOD

Maintenance and servicing of the sailplane are provided in the L 23 SUPER-BLANIK sailplane Maintenance Manual Do - L 23 1031.3 (see Section 5).



SECTION 9

Supplements

CONTENTS

- 9.1 Introduction
- 9.2 List of inserted Supplements
- 9.3 Supplements inserted



9.1 INTRODUCTION

Section 9 of this Sailplane Flight Manual provides supplemental information for optional equipment which is installed on the sailplane and additionally it may contain the supplementary information on sailplane operation.

The information contained in this document supplements or supersedes the basic Sailplane Flight Manual where covered in the sections contained herein. For limitations, procedures and performance not contained in this supplement, consult the basic Sailplane Flight Manual.

9.2 LIST OF INSERTED SUPPLEMENTS

Date of insertion	Doc. No.	Title of inserted supplement
	1	Not used
	2	Not used
	3	Not used
Feb 15/02	4	ILEC SN 10 Sailplane Computer
Feb 15/02	5	VHF DITTEL FSG 71M Transceiver
	6	Emergency Locator Transmitter Ameri-King AK-450 ELT
Feb 15/02	7	Volkslogger VL-01 GPS Flight Data Recorder
Feb 15/02	8	Front and rear cockpits



SUPPLEMENT No.4

ILEC SN 10 Sailplane Computer

Serial Number	029005
Registration number	N410BA

This supplement must be attached to the Sailplane Flight Manual when the ILEC SN 10 Sailplane Computer is installed.

The information contained herein supplements or supersedes the basic manual only in those areas listed herein. For limitation, procedures and performance information not contained in this supplement, consult the basic Sailplane Flight Manual.

Revision No.	Revised Pages	Description of Revision	Date

Not subject to CAA approval



SECTION 1 - GENERAL - Not affected

SECTION 2 - LIMITATIONS

System function and accuracy was not judged by CAA Czech Republic.
Do not use ILEC as primary information source.

SECTION 3 - EMERGENCY PROCEDURES - Not affected

SECTION 4 - NORMAL PROCEDURES

ILEC SN 10 Sailplane Computer operation

Note: Detailed description of the operation is mentioned in the SN 10 User Manual, Software Version 2.21, revision date 17-May-2001.

Battery switch on the front instrument panel must be on before SN 10 switching on.

SN 10 is switched on by turning clockwise of the Off/Vol knob. Audio signals volume is set by means the same knob.

WARNING: SN 10 is not a replacement for primary flight instruments and pilot's decisions. In case of incorrect inputs, the SN 10 will display incorrect and possibly dangerous information. All decisions during flight must be made by the pilot!

Suggested preflight checklist for competition mode:

(see Ilec SN 10 User Manual, Appendix B)

- Verify altimeter setting in the Alt field
- Set desired finish altitude in the Fin field (field elevation plus safety height)
- Check battery voltage in the Volts field
- Set timers if applicable (STI and RST min fields)
- Set the final glide Wind setting from the weather briefing
- Set Water and Bugs

(cont.)



- Set the planned Task
- Flight recorder:
Clear any prior-day flight record (Reset).
Set point Cylinder size.

Suggested preflight checklist for club mode:
(see Ilec SN 10 User Manual, Appendix B)

CAUTION: IF YOU TURN OFF THE SN 10 SOME SETTINGS WILL RESET TO THEIR DEFAULT VALUE. DO NOT TURN OFF THE SN 10 AFTER YOU DONE YOUR CHECKLIST.

- Verify the altimeter setting in the Alt field.
- Set desired arrival altitude over the ground in the Arv field.
- Set Water and Bugs (on the Club Settings page)
- Check battery voltage Volts (on the Club Settings page)
- Set the final glide Wind setting from the weather briefing (on the Club Wind page)

Using the SN 10 with a Volkslogger

Description is mentioned in the SN 10 User Manual, Appendix G.

Volkslogger flight data recorder is switched on automatically when SN 10 is switched on.

SECTION 5 - PERFORMANCE - Not affected

SECTION 6 - WEIGHTS AND BALANCE

SN 10 sailplane computer: weight 1.57 lb (0.71 kg),
arm -72.05 in (-1,830 mm)

SN 10-2 repeater: weight 0.93 lb (0.420 kg), arm -22.44 in (-570 mm)

Variometer RAZ: weight 0.40 lb (0.18 kg), arm -69.69 in (-1,770 mm)



SECTION 7 - SAILPLANE AND SYSTEM DESCRIPTION

Ilec SN 10 sailplane computer is installed in the sailplane. Control boxes with display are located on the front and rear instrument panel. Inputs from temperature probe, pitot-static system and GPS unit from Volkslogger are led into SN 10. Data are presented on the displays and RAZ variometer which is located on the front instrument panel.

Ilec SN 10 Sailplane Computer controls

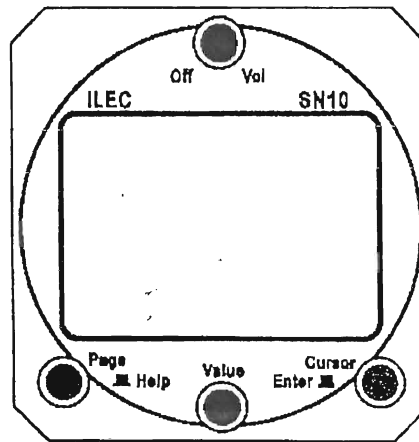

- Off/Vol knob:** switches on SN 10 by turning clockwise and sets audio signals volume. Repeater on the rear instrument panel has not this knob.
- Page/Help knob/button:** selects SN 10 pages by turning, when it is held depressed displays help text for the currently selected field. When you release the button, the help text disappears and the normal screen is restored. For some fields a second page of help is provided when you release button, press and release button a second time to clear the second page.
- Cursor/Enter knob/button:** turning selects active field on the page, pressing enters some data
- Value knob:** turning changes the value of the currently selected field

SECTION 8 - SAILPLANE HANDLING, CARE AND MAINTENANCE Not affected



L 23 SUPER - BLANIK

686 04 KUNOVICE
CZECH REPUBLIC

SAILPLANE FLIGHT MANUAL

Do - L23 .1014.5

RECOMMENDED ILEC SETTING

See item 5.6 and 5.7 of the SN 10 User Manual, Software Version 2.21, revision date 17-May-2001.

5.6 Glider polar setup

Do not use default setting for L 23 (it is not quite exact), create new custom polars Custom 1 and Custom 2.

Custom 1 (without wing tip extensions) - Std. weight 530 kg

Airspeed	KIAS	km/hour IAS	Vertical speed	fpm	m/s
V	49	91	S	178	0.90
V	74.5	138	S	401	2.04
V	100	185.3	S	922	4.68

Custom 2 (with wingtip extensions) - Std. weight 530 kg

Airspeed	KIAS	km/hour IAS	Vertical speed	fpm	m/s
V	47.5	88	S	158	0.80
V	73.7	136.7	S	392	1.99
V	100	185.3	S	941	4.78

Insert this page behind Supplement No.4



L 23 SUPER - BLANIK

686 04 KUNOVICE
CZECH REPUBLIC

SAILPLANE FLIGHT MANUAL

Do - L23 .1014.5

5.7 Airspeed calibration setup

KIAS	IAS km/hour	KCAS	CAS km/hour
32	60	36	66
43	80	45	83
54	100	55	102
65	120	65	121
76	140	76	141
86	160	87	162
97	180	98	182
108	200	109	202
121	225	123	228
135	250	137	253

Insert this page behind Supplement No.4



SUPPLEMENT No.5

VHF DITTEL FSG 71M Transceiver

Serial Number	029005
Registration Number	N410BA

This supplements must be attached to the Sailplane Flight Manual when the VHF DITTEL FSG 71M Transceiver is installed. The informations contained herein supplements or supersedes the basic manual only in those areas listed herein. For limitations, procedures and performance information not contained in this supplement, consult the basic Sailplane Flight Manual.

Revision No.	Revised Pages	Description of Revision	Date



SECTION 1 - GENERAL - Not affected

SECTION 2 - LIMITATIONS - Not affected

SECTION 3 - EMERGENCY PROCEDURES - Not affected

SECTION 4 - NORMAL PROCEDURES

Operating instructions for the VHF DITTEL FSG 71M transceiver

Battery switch must be on before transceiver switching-on.

Turn ON the transceiver with the right toggle switch (lever up ON). Select the desired operating frequency by rotating the increment/decrement knobs either clockwise or counterclockwise. A clockwise rotation will increment the previous frequency while a counterclockwise rotation will decrement the previous frequency. The larger inside knob will change the MHz-portion, the smaller outside knob will change the kHz-portion. At one band-edge (000 or 975 kHz) the following 25 kHz change will wrap around to the other band-edge. Transmission is switched on by push-to-talk button on the front and rear control stick. Listening is ensured via speaker box which is common for both cockpits.

Frequency selection:

To select the desired operating frequency rotate the channel selector fully clockwise. To tune the radio to a stored operating frequency rotate the channel selector switch to the desired channel No. (1-10). The receiver is always tuned to the frequency appearing in the display.

Set the left toggle switch to "Squelch OFF"-position (lever down) to override the automatic squelch and rotate the "VOL" knob for desired listening level on the noise being produced by the receiver. Set the left toggle switch to "SQ" (lever up) to activate the automatic squelch.

A warm-up period is not required. However, at temperatures of -20°C , the LC display needs approx. 1 sec. until it is fully visible when frequency is changed.

For transmit operation select the desired frequency, depress the push-to-talk button and speak into the microphone. The microphone must be kept close to the lips in order to cancel noise like from the engine etc. Enunciate clearly at a constant loudness. During transmit operation, the yellow LED "TX"-indicator will light on the front panel, signaling that the push-to-talk button is depressed.

During receive operation rotate the "VOL" knob for desired volume.

Caution:

Frequent transmitting and loud receiver volume reduce available operating time.



Programming the Channel Frequency Memory:

The FSG 71M transceiver is equipped with 10 memory cells which are able to store one frequency each in the range from 118.000 to 136.975 MHz. The stored frequencies are non-volatile.

Channel Frequency setting:

- Rotate channel selector knob fully clockwise.
- Select the desired frequency by rotating MHz- and kHz knobs.
- Rotate channel selector knob to desired channel number (1 to 10).
- Enter the frequency by depressing (approx. 1 sec.) the store button (STO) into the memory. If a frequency is already stored in that certain channel it will be overwritten. The function of the STO button is electrically delayed to reduce memory loss caused by accident touching.

Recall of Stored Frequencies:

Rotate channel selector knob to desired channel number. The stored frequency will appear on the display and the transceiver is tuned.

Caution:

If the built-in battery of the electronic memory is defective, the memory content is lost when the unit is switched OFF. For safety reasons the memory battery should be changed every five to six years by authorized personnel (recommended date of change see separate tag unit).

Note:

Detailed operating instructions are mentioned in the Installation & Operation Manual Transceiver FSG 71M (Document No.: 027.HB.00E, Revision No.: (Reprint)1, Data/Issue: July 1998)

SECTION 5 - PERFORMANCE - Not affected

SECTION 6 - WEIGHTS AND BALANCE

Transceiver block: Weight 5.2 lb (2.36 kg), arm -38 in (-963 mm)

Battery F10023: Weight 7.6 lb (3.45 kg), arm 14.6 in (+370 mm)

SECTION 7 - SAILPLANE AND SYSTEM DESCRIPTIONS

VHF DITTEL FSG 71M controls

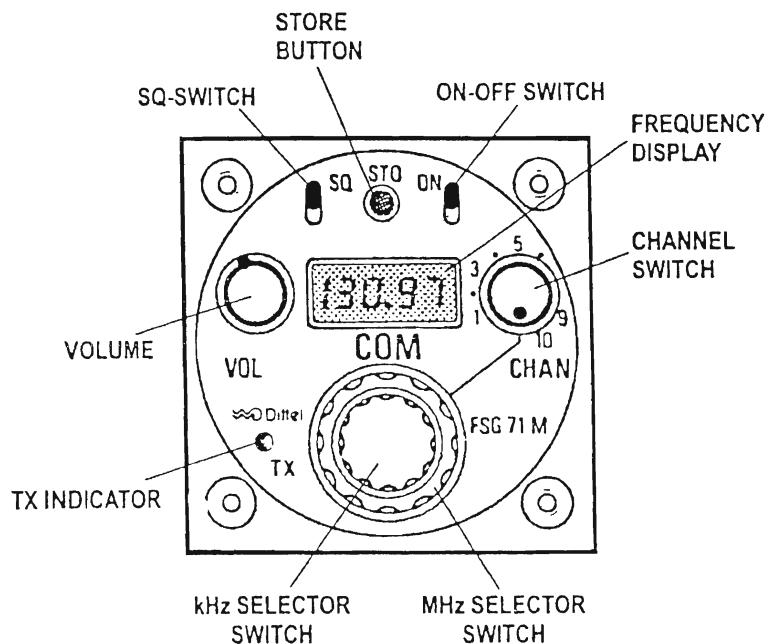

Switch ON/OFF: Lever down: power OFF, Lever up (ON): unit supplied with power.

Potentiometer VOL: To increase the receiving volume rotate the knob clockwise.

Switch SQ: Lever down: the squelch circuit is off (basic receiver noise is audible). Lever up: common position, the squelch circuit is activated (only reception of signals above SQ-treshold).

Frequency display (5-digit liquid crystal display, internal lighted): Shows the operation frequency in digital form set from 118.00 to 136.97 MHz. Last digit "5" or "0" does not appear. Blinks if power supply drops below 11 V DC.

kHz Selector: Sets frequency in 25 kHz increments (000 - 975).

MHz Selector: Sets frequency in 1 MHz increments (118. - 136.)

TX indicator (Yellow LED): Lights during depressing the push-to-talk button.

CHAN (rotary knob): Knob fully clockwise: frequency free selectable by MHz- and kHz knobs. Knob on position 1 trough 10: recall of channel frequencies.



STO button: By depressing the STORE-button the displayed frequency is entered in one of the 10 electronic memories provided that the CHAN switch is at one of the 1 through 10 position.

SECTION 8 - SAILPLANE HANDLING, CARE AND MAINTENANCE - Not affected



SUPPLEMENT No. 7

Volkslogger VL-01 GPS Flight Data Recorder

Serial Number	029005
Registration Number	N410BA

This supplement must be attached to the Sailplane Flight Manual when the Flight Data Recorder Volkslogger VL-01 GPS is installed.

The information contained herein supplements or supersedes the basic manual only in those areas listed herein. For limitation, procedures and performance information not contained in this supplement, consult the basic Sailplane Flight Manual.

Revision No.	Revised Pages	Description of Revision	Date

Not subject to CAA approval

SECTION 7 - SAILPLANE AND SYSTEM DESCRIPTION

Volkslogger flight data recorder is installed in the sailplane. It is approved FAI (FAI - Sporting Code, Section 3, Annex B) for competition using. Maximum record capacity is up to 30 hours. Geographic attitude, GPS altitude and barometric altitude are recorded.

Volkslogger contains GPS receiver with integral antenna. Volkslogger can be used for navigation purposes and to obtain information stored in database (25 pilot names, 25 task - each max. 10 way points and 500 waypoints - airport included).

Recorder is located on top of the rear instrument panel to ensure receiving from GPS satellites. It is controlled by three keys located on the instrument front side next to display.

Volkslogger VL-01 GPS Flight Data Recorder controls

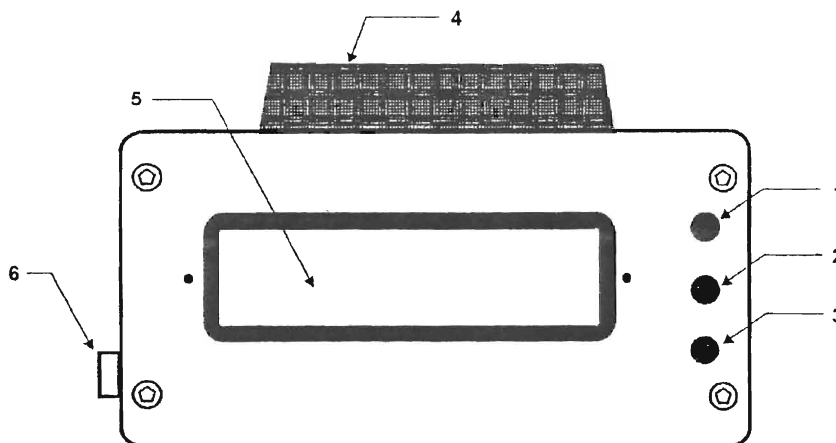

1 to 3 - control keys, 4 - GPS antenna, 5 - display, 6 - plug

The keys have different functions depending on the display and the operating mode of the recorder. For instance key 1 has the function of an escape key (exiting the menu level to the next higher level). Key 2 has the next function. You can select the displayed menu items with it. Beside this, in modes where you can change a value, key 2 can be considered a (-) key, as (+) key use key 3. Key 3 also has the property of an enter key. With it you can go to the selected menu. Every key has an auto repeat function, which means that if it is held depressed longer than 0.5 sec, it acts as if it is pressed repeatedly in rapid succession.

SECTION 8 - SAILPLANE HANDLING, CARE AND MAINTENANCE

Not affected



SUPPLEMENT No.8

FRONT AND REAR COCKPITS

Serial Number	029005
Registration Number	N410BA

This supplement must be attached to the Sailplane Flight Manual of the above mentioned sailplane serial number. The informations contained herein supplements or supersedes the basic manual only in those areas listed herein. For limitations, procedures and performance information not contained in this supplement, consult the basic Sailplane Flight Manual.

Revision No.	Revised Pages	Description of Revision	Date



SECTION 1 - GENERAL - Not affected

SECTION 2 - LIMITATIONS - Not affected

SECTION 3 - EMERGENCY PROCEDURES - Not affected

SECTION 4 - NORMAL PROCEDURES - Not affected

SECTION 5 - PERFORMANCE - Not affected



SECTION 6 - WEIGHTS AND BALANCE

6.6 EQUIPMENT LIST

Standard (S) items must be installed for all operations. Optional (O) items are available for installation. Installed items for each sailplane equipment list will be marked with an "X" and included in the Empty Weight/c.g. pos of the Balance Record.

	S	O	Subject	Type	Mass lb (kg)	Arm from the reference plane (rib No. 1) ft (mm)	Date of installation
1	X		Altimeter	UI5934P-3 front instr.panel rear instr.panel	1.75 (0.85)	- 5.82 (-1774) - 1.81 (-551)	5.3.02 LZ 55 fl
2	X		Airspeed indicator	LUN 1106.15-8 front instr.panel rear instr.panel	0.88 (0.4)	- 5.83(-1777) - 1.82(-555)	5.3.02 LZ 55 fl
3		X	Vertical speed indicator ± 10 knots	LUN 1141.04 front instr. panel rear instr.panel	1.06 (0.48)	- 5.87(-1789) - 1.87(-570)	5.3.02 LZ 55 fl
4		X	Magnetic compass	LUN 1221.1-8 front instr. panel rear instr.panel	0.23 (0.105)	- 5.79(-1765) - 1.79(-546)	5.3.02 LZ 55 fl
5		X	Accelerometer	AM-10 front front front instr. panel rear instr. panel	0.55 (0.25)	-5.83(-1777) -1.82(-555)	5.3.02 LZ 55 fl

(Cont.)



	S	O	Subject	Type	Mass lb (kg)	Arm from the reference plane (rib No. 1) ft (mm)	Date of installation
6		X	Vertical speed indicator	SN 10 front instr. panel	0.73 (0.33)	-5.83(-1777)	5.3.02 LZ 55
7		X	Sailplane computer	SN 10B front instr. panel	1.54 (0.7)	-5.83(-1777)	5.3.02 LZ 55
8		X	Repeater	SN 10-2 rear instr. panel	0.92 (0.42)	-1.82(-555)	5.3.02 LZ 55
9		X	Transceiver	DITTEL FSG 71M front instr. panel	5.2 (2.36)	-3.16(-963)	5.3.02 LZ 55
10		X	Battery	Battery F10023	7.6 (3.45)	+1.21(+370)	5.3.02 LZ 55
11		X	PAINT	POLYURETAN	18.7 (8.5)	+3.4 (1.04)	5.3.02 LZ 55
12							
13							
14							

SECTION 7 - SAILPLANE AND SYSTEM DESCRIPTIONS

7.4 FRONT COCKPIT

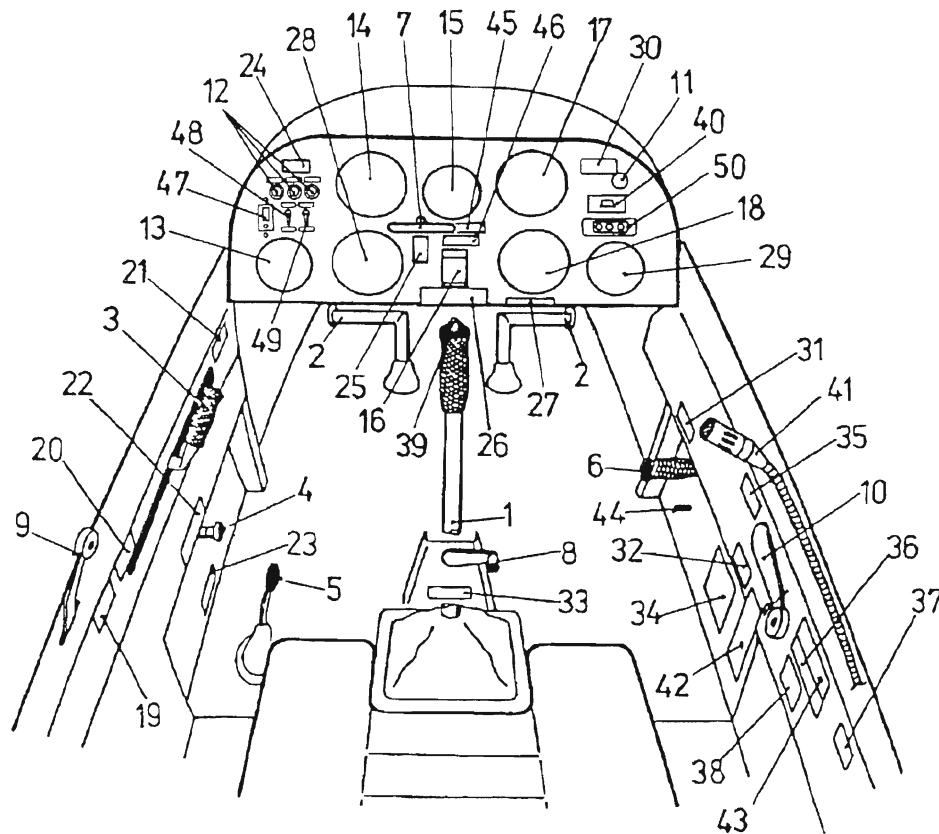

FIG. 7-2

(1)Control column, (2)Rudder pedals, (3)Airbrake handle, (4)Elevator trim handle, (5)Wheel brake handle, (6)Landing gear handle, (7)Rope release mechanism, (8)Rudder pedals adjustment, (9)Cockpit hood opening handle, (10)Handle of canopy jettison, (11)Air vent pull rod with handle, (12)Fuses, (13)Vertical speed indicator SN 10, (14)Airspeed indicator, (15)Accelerometer, (16)Compass, (17)Altimeter, (18)Vertical speed indicator, (19)Label "Canopy lift off", (20)Label "Airbrakes extended", (21)Label "Airbrakes retracted", (22)Label "Elevator trim control", (23)Label "Wheel brake", (24)Label "Max. airspeeds", (25)Label "Tow release", (26)Label "Max. airspeeds", (27)Identification number, (28)Sailplane computer SN 10B, (29)DITTEL FSG 71M transceiver, (30)Label "Air vent", (31)Label "Landing gear extended", (32)Label "Landing gear retracted", (33)Label "Adjustment of pedals", (34)Label "Max. pilot weight", (35)Label "Canopy jettison", (36)Label "Operating limitations", (37)Label "Seat position", (38)Label "Center of gravity", (39)Radio control button, (40)DATA PORT, (41)Microphone, (42)Deviation chart, (43)Label "Max. allowable speed vs altitude", (44)Positional pin of landing gear opened and locked position (the landing gear handle must be located in front of the positional pin in flight direction), (45)Label "Manoeuvres with wing tip extensions forbidden", (46)Label "Max. airspeed with wing tip extensions. (47)Battery indicator, (48)Switch Battery 1/Battery 2", (49)Battery switch ON/OFF, (50) ELT Remote unit (optional).

7.5 REAR COCKPIT

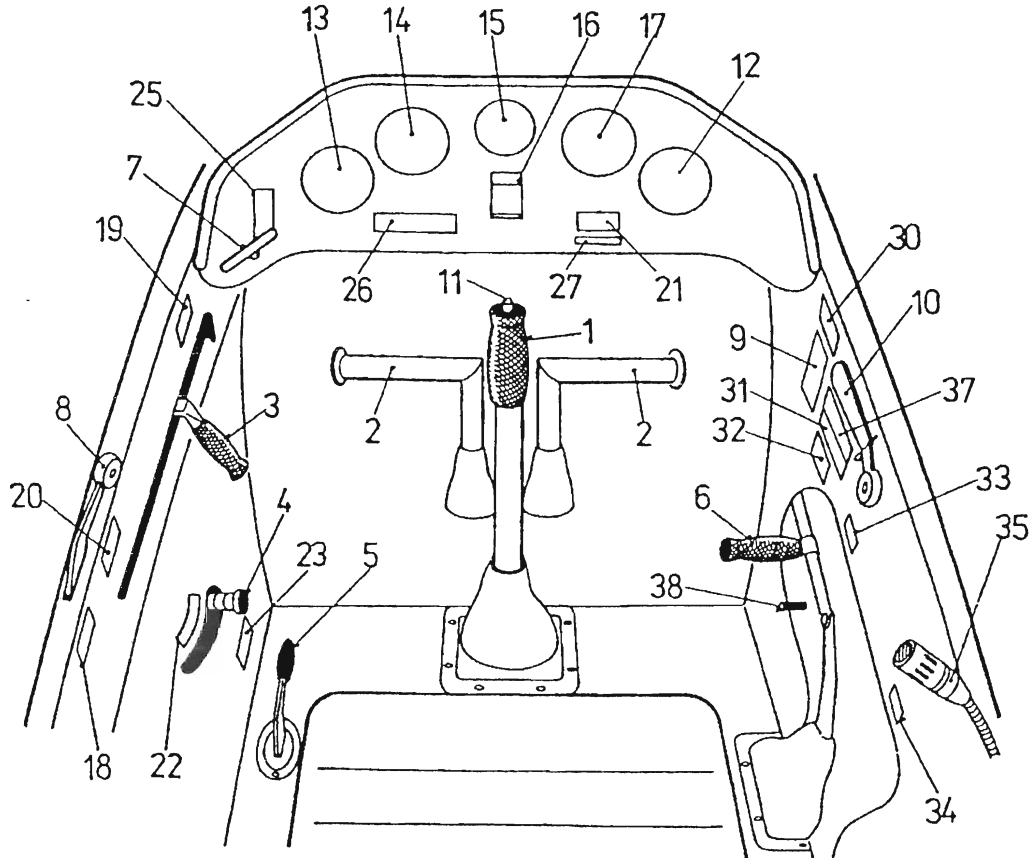

FIG. 7-3

- (1)Control column, (2)Rudder pedals, (3)Airbrake handle, (4)Elevator trim handle, (5)Wheel brake handle, (6)Landing gear handle, (7)Rope release mechanism, (8)Cockpit hood opening handle, (9)Deviation chart, (10)Handle of canopy jettison, (11)Radio control button, (12)Vertical speed indicator, (13)Repeater SN 10-2, (14)Airspeed indicator, (15)Accelerometer, (16)Compass, (17)Altimeter, (18)Label "Airbrakes extended", (19)Label "Airbrakes retracted", (20)Label "Canopy lift off", (21)Label "Max. airspeeds", (22)Label "Elevator trim control", (23)Label "Wheel brake", (24)Not used, (25)Label "Tow release", (26)Label "Max. airspeeds", (27)Identification number, (28)Not used, (29)Not used, (30)Label "Canopy jettison", (31)Label "Operating limitations", (32)Label "Center of gravity", (33)Label "Landing gear extended", (34)Label "Landing gear retracted", (35)Microphone, (36)Not used, (37)Label "Max. allowable speed vs altitude", (38)Positional pin of landing gear opened and locked position (the landing gear handle must be located in front of the positional pin in flight direction)

SECTION 8 - SAILPLANE HANDLING, CARE AND MAINTENANCE - Not affected